

The Unusual Behavior of
Excess Low-Frequency Flux Noise
at
Temperatures Below 1K

Fred Wellstood
Joint Quantum Institute
and CNAM
Department of Physics
University of Maryland,
College Park, MD

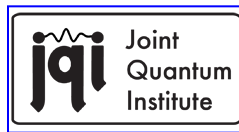

Cristian Urbina
Centre d'Etudes Nucléaires
de Saclay,
Saclay, France



John Clarke
Department of Physics
and LBL
University of California
Berkeley, CA



Outline

I. Introduction to $1/f$ flux noise

II. Experimental arrangements

III. Some basic facts about excess flux noise

IV. Some details:

how we know its flux noise,

how we know the electron temperature,

distribution of amplitudes,

device parameters and other devices

V. Conclusions

Nakamura et al. results on Flux Qubit with best coherence

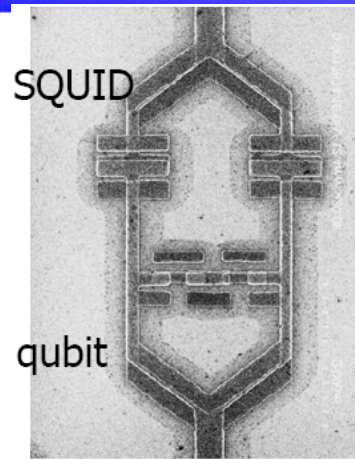

$\Delta/h = 2.557$ GHz, $I_p = 157$ nA

$2.3 \mu\Phi_0/\text{Hz}^{1/2}$ @ 1 Hz

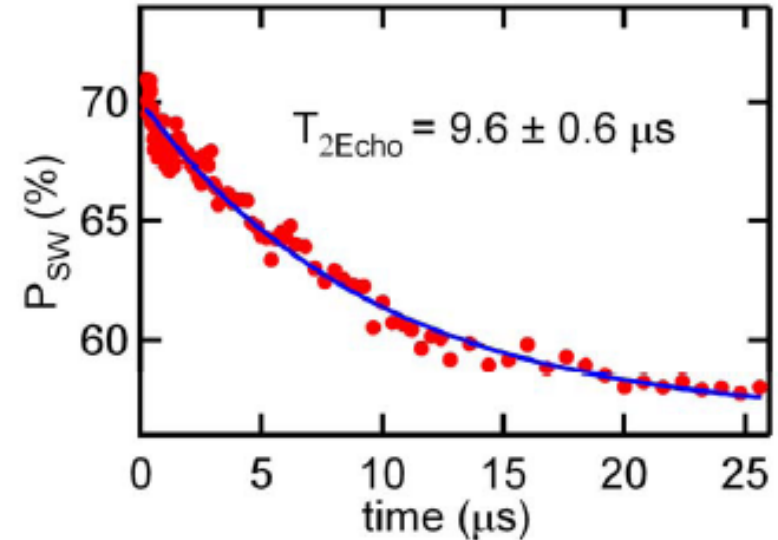
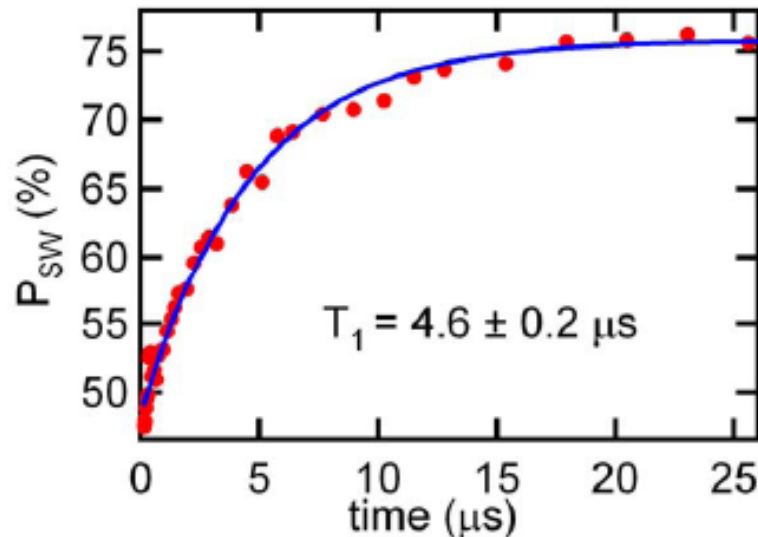
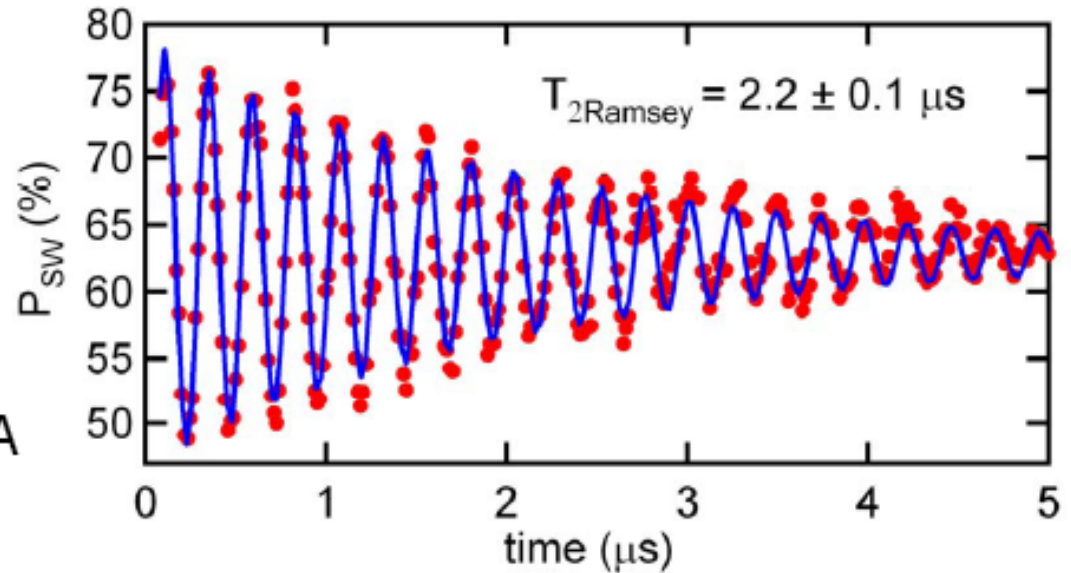

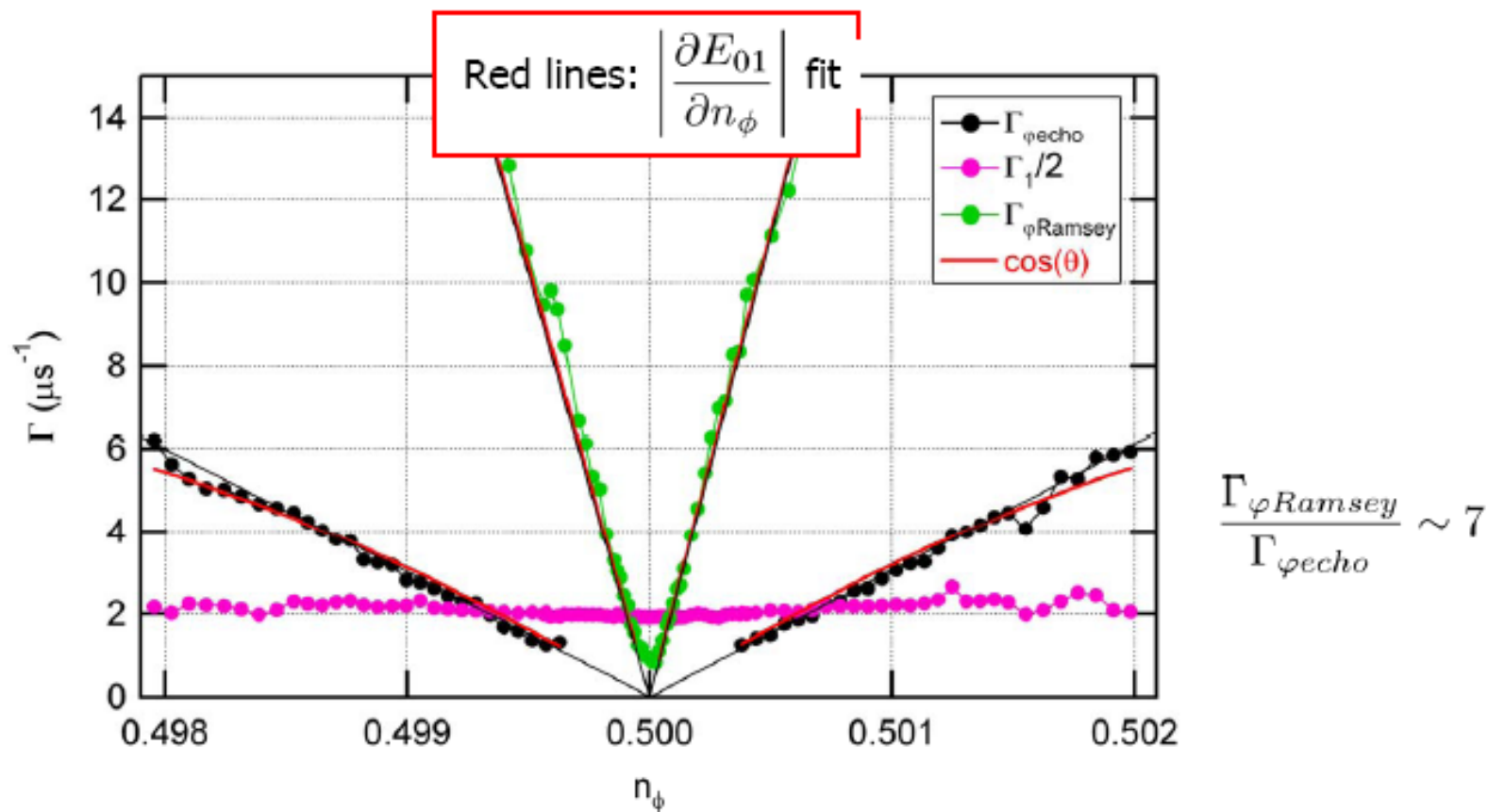

For $S_{n_{\phi}}(\omega) = \frac{A}{|\omega|}$ $P_{echo}(t) = \exp\left(-\frac{\Gamma_1}{2}t\right) \exp(-\Gamma_{\varphi echo}^2 t^2)$ $\Gamma_{\varphi echo} = \frac{\sqrt{A \ln 2}}{\hbar} \left| \frac{\partial E_{01}}{\partial n_{\phi}} \right|$

$\rightarrow A \sim (10^{-6} \Phi_0)^2$

Flux noise, not charge noise nor critical current noise

Measured flux noise at 1Hz for several SQUIDs

"Low Frequency Noise in dc Superconducting Quantum Interference Devices Below 1K",
F. C. Wellstood, C. Urbina, and J. Clarke, Appl. Phys. Lett., 50, 772 (1987).

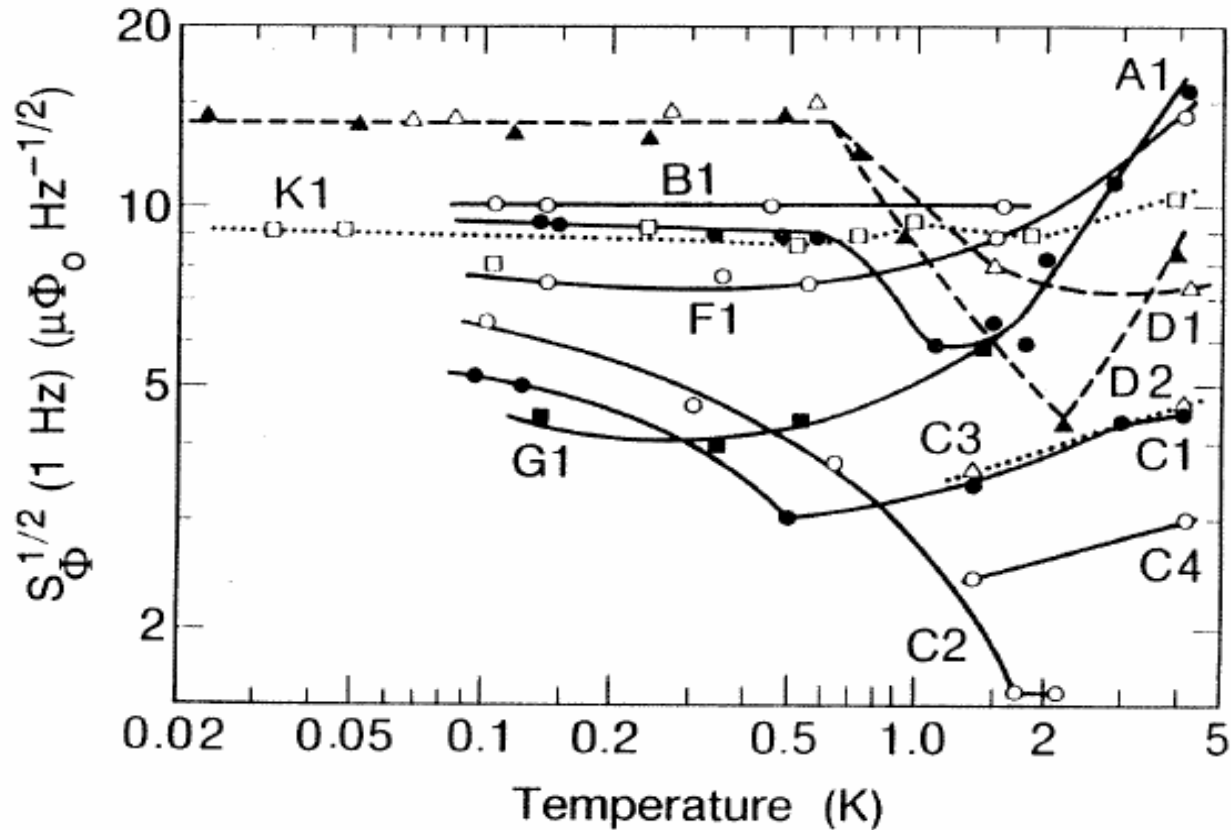

- noise **increases** as T **decreases** below 1 K and then levels off
- noise roughly independent of SQUID size
- different devices with same shape produce similar noise

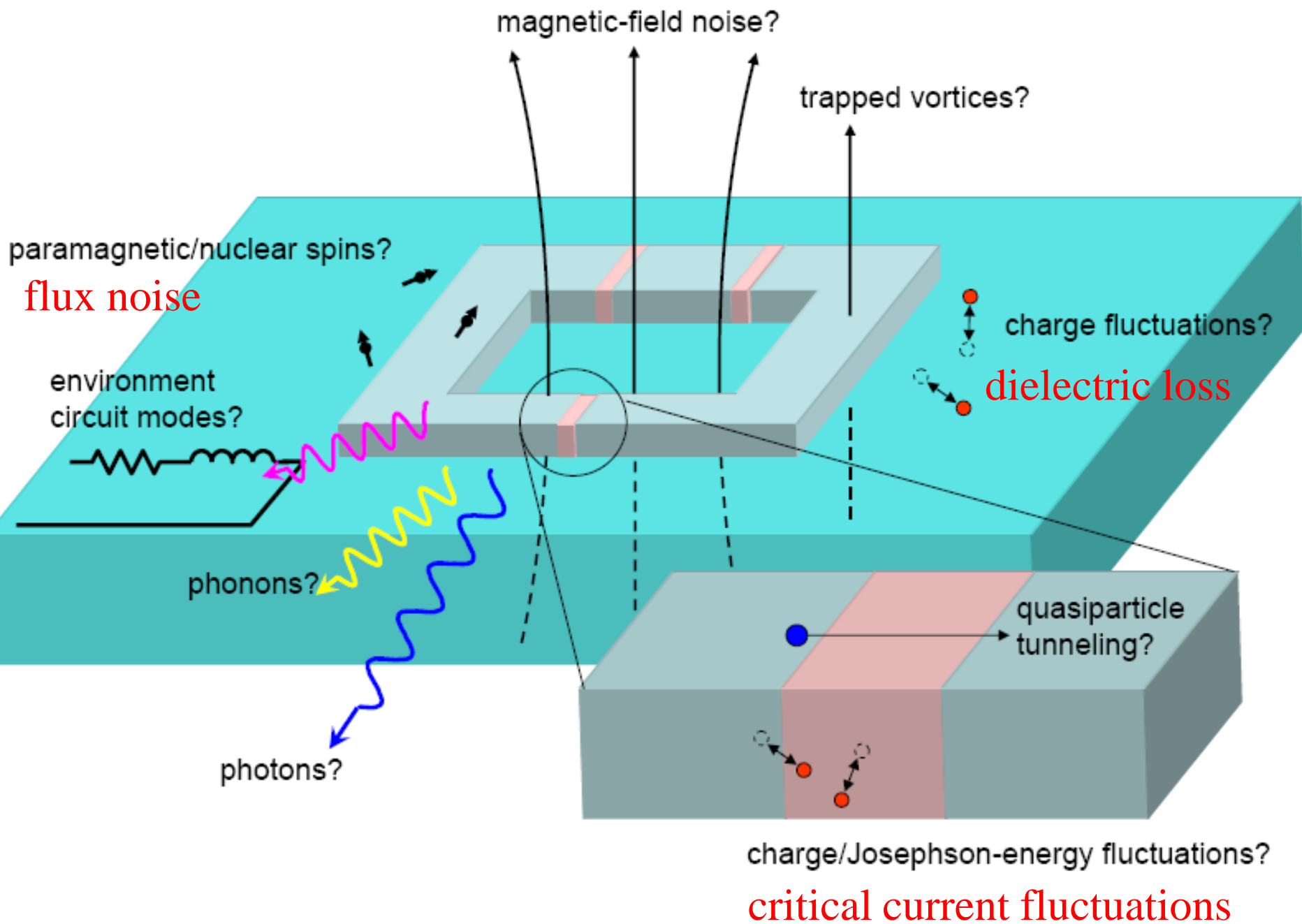

The accepted explanation for 1/f noise (Dutta and Horn)

(1) Assume many two-level (magnetic dipole) fluctuators with equal well depths

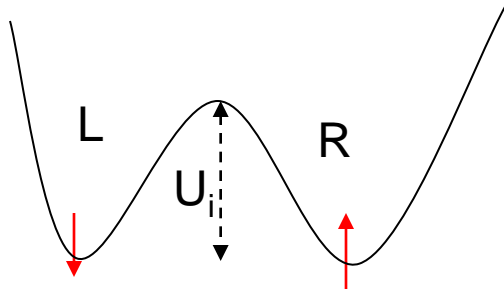

(2) suppose that each system fluctuates randomly between L and R with mean lifetime:

$$\tau_L = \tau_R = \tau_o e^{U_i/kT} = 2\tau_i$$

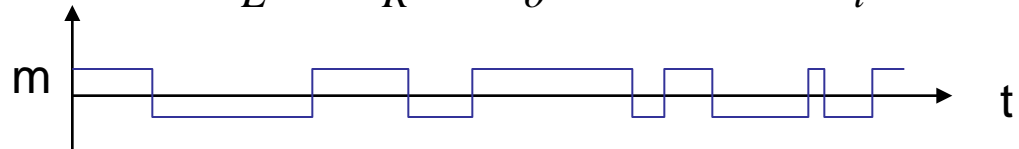

(3) The magnetic moment of each fluctuator gives telegraph noise that produces a (1-sided) power spectrum (Machlup, J.A.P. 1954)):

$$S_{mi}(f) = \frac{4\sigma_m^2 \tau_i}{1 + \omega^2 \tau_i^2} \quad \text{Lorentzian spectrum}$$

Note that: the mean square standard deviation in the magnetic moment from the i-th fluctuator is:

$$\sigma_m^2 = \int_0^{\infty} S_{mi}(f) df = \int_0^{\infty} \frac{4\sigma_m^2 \tau_i}{1 + \omega^2 \tau_i^2} df = \frac{4\sigma_m^2}{2\pi} \int_0^{\infty} \frac{2\pi \tau_i df}{1 + \omega^2 \tau_i^2}$$

$$= \frac{2\sigma_m^2}{\pi} \int_0^{\infty} \frac{dy}{1 + y^2} = \frac{2\sigma_m^2}{\pi} (a \tan(\infty) - a \tan(0)) = \sigma_m^2$$

independent
of τ_i

The accepted explanation for 1/f noise (Dutta and Horn)

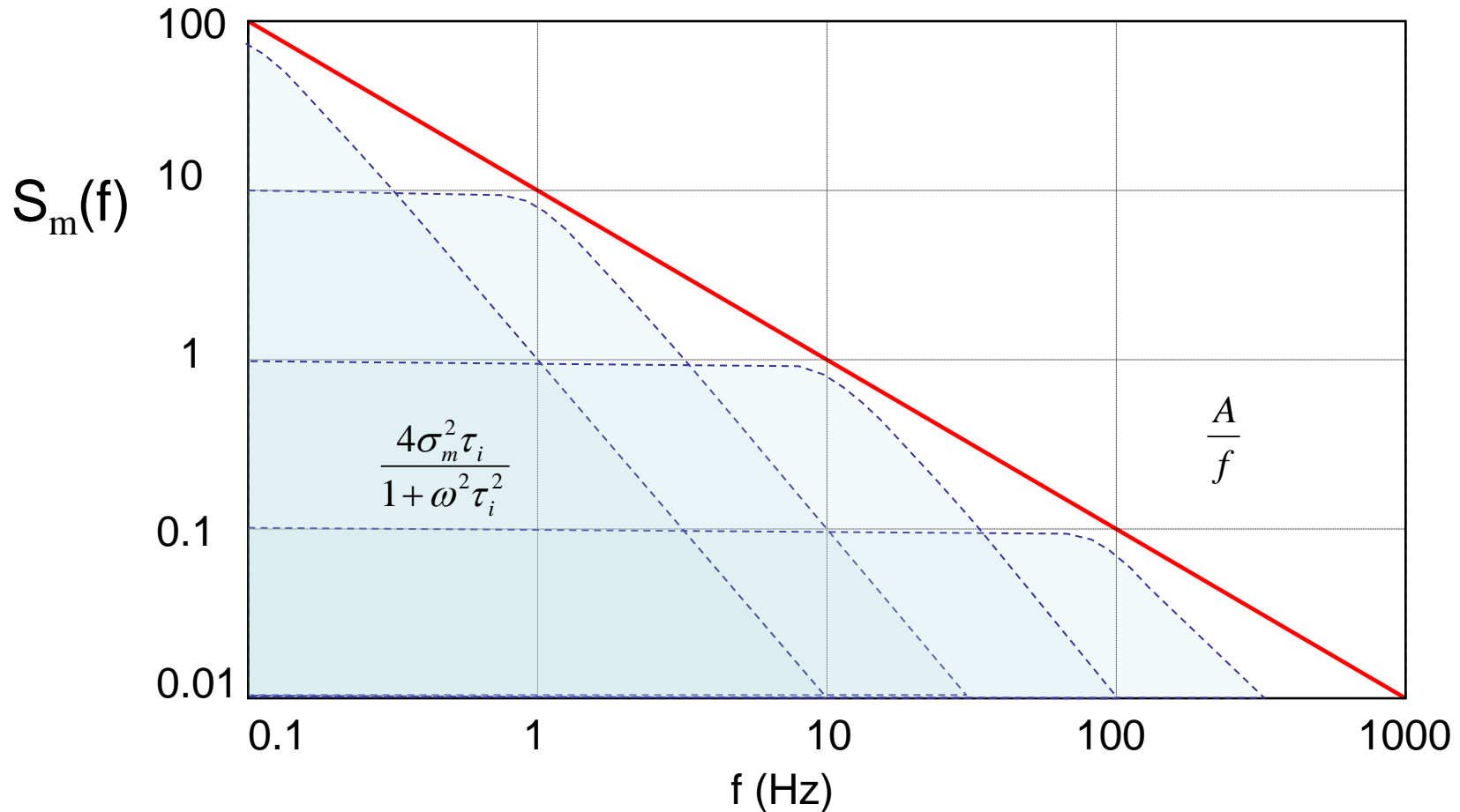

need equal number of Lorentzians in each decade of frequency or to get 1/f

.....
$$D(\tau)d\tau \sim \frac{d\tau}{\tau}$$

(4) Assume that there is a uniform distribution of barriers U , i.e. $D(U) dU = C'' dU$

notice that $U = kT \ln(2\tau/\tau_o)$ $D(\tau) = D(U) \frac{dU}{d\tau} = \frac{C'' kT}{\tau}$

(5) The total noise spectrum is

$$S_m^{tot}(f) = \int_0^\infty S_{mi}(f) D(U) dU = 4\sigma_m^2 C'' \int_0^\infty \frac{\tau_i}{1 + \omega^2 \tau_i^2} dU$$

Now substitute: $\tau = \frac{\tau_o}{2} e^{U/kT}$

and find: $S_m^{tot}(f) = 4\sigma_m^2 C'' \int_0^\infty \frac{\frac{\tau_o}{2} e^{U/kT}}{1 + \omega^2 \frac{\tau_o^2}{4} e^{2U/kT}} dU$

change variables to $y = \frac{\omega \tau_o}{2} e^{U/kT}$

1/f noise goes away as T decreases

$$S_m^{tot}(f) = \frac{4\sigma_m^2 C'' kT}{\omega} \int_0^\infty \frac{\frac{\omega \tau_o}{2} e^{U/kT}}{1 + \omega^2 \frac{\tau_o^2}{4} e^{2U/kT}} \frac{dU}{kT} = \frac{4\sigma_m^2 C'' kT}{\omega} \int_0^\infty \frac{dy}{1 + y^2} = \frac{\sigma_m^2 C'' kT}{f}$$

(4) Assume that there is a uniform distribution of barriers U , *i.e.* $D(U) dU = C'' dU$

notice that $U = kT \ln(2\tau/\tau_o)$ $D(\tau) = D(U) \frac{dU}{d\tau} = \frac{C'' kT}{\tau}$

(5) The total noise spectrum is

expected noise to scales as T/f , which is not seen!

Kenyon et al. found T^2/f for uniform distribution of well barrier heights and well asymmetry...

T^2/f or T/f works well for critical current noise, charge noise and might explain flux noise above 1 K but not below 1 K

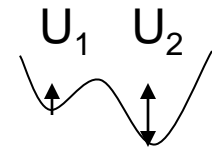

playing around with $D(U)$ can yield different slopes, but the temperature dependence doesn't look like data

$$S_m^{tot}(f) = \frac{4\sigma_m^2 C'' kT}{\omega} \int_0^\infty \frac{\frac{\omega\tau_o}{2} e^{U/kT}}{1 + \omega^2 \frac{\tau_o^2}{4} e^{2U/kT}} \frac{dU}{kT} = \frac{4\sigma_m^2 C'' kT}{\omega} \int_0^\infty \frac{dy}{1 + y^2} = \frac{\sigma_m^2 C'' kT}{f}$$

Flux noise power from fluctuators uniformly spread in 3D

consider flux coupled into i-th small loop when current I_s flows in SQUID

$$\Phi_{sa} = I_s M_i = \bar{B}_s(r, r') \cdot \bar{A}_a$$

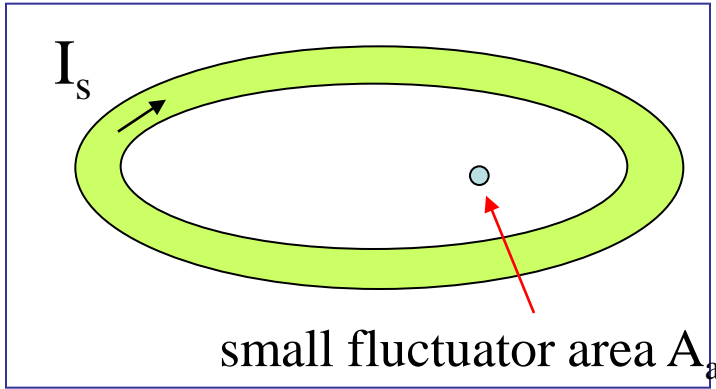

mutual inductance between SQUID and i-th small loop $\rightarrow M_i = \frac{\bar{B}_s(r, r') \cdot \bar{A}_a}{I_s}$

Flux coupled into SQUID by i-th small loop is:

$$\Phi_i = M_i I_a = \frac{\bar{B}_s(r, r') \cdot \bar{A}_a}{I_s} I_a$$

Let $I_a = |I_a| \sigma$, where $\sigma = +/- 1$.

Flux noise power spectral density from current fluctuating in i-th small loop

$$S_{\Phi_i}(f) = \left[\frac{\bar{B}_s(\bar{r}, \bar{r}') \cdot \bar{A}_{aj}}{I_s} \right]^2 I_a^2 S_{\sigma_i}(f)$$

Total flux noise power spectral density from all small loops in half-space below the SQUID

$$S_{\Phi} = \sum_{i=1}^N S_{\Phi_i} = \frac{1}{2} \int \left[\frac{\bar{B}_s(\bar{r}, \bar{r}') \cdot \bar{A}_{aj}(\bar{r}')}{I_s} \right]^2 I_a^2 S_{\sigma_i} n dV'$$

$$= \frac{n}{2} \left(\frac{I_a A_a}{I_s} \right)^2 \left(\int |\bar{B}_s(\bar{r}, \bar{r}')|^2 \langle \cos^2(\theta(\bar{r}')) \rangle dV' \right) S_{\sigma_i} = \boxed{\frac{1}{6} n \mu_o \mu_B^2 L \langle S_{\sigma} \rangle}$$

Flux noise measurement technique

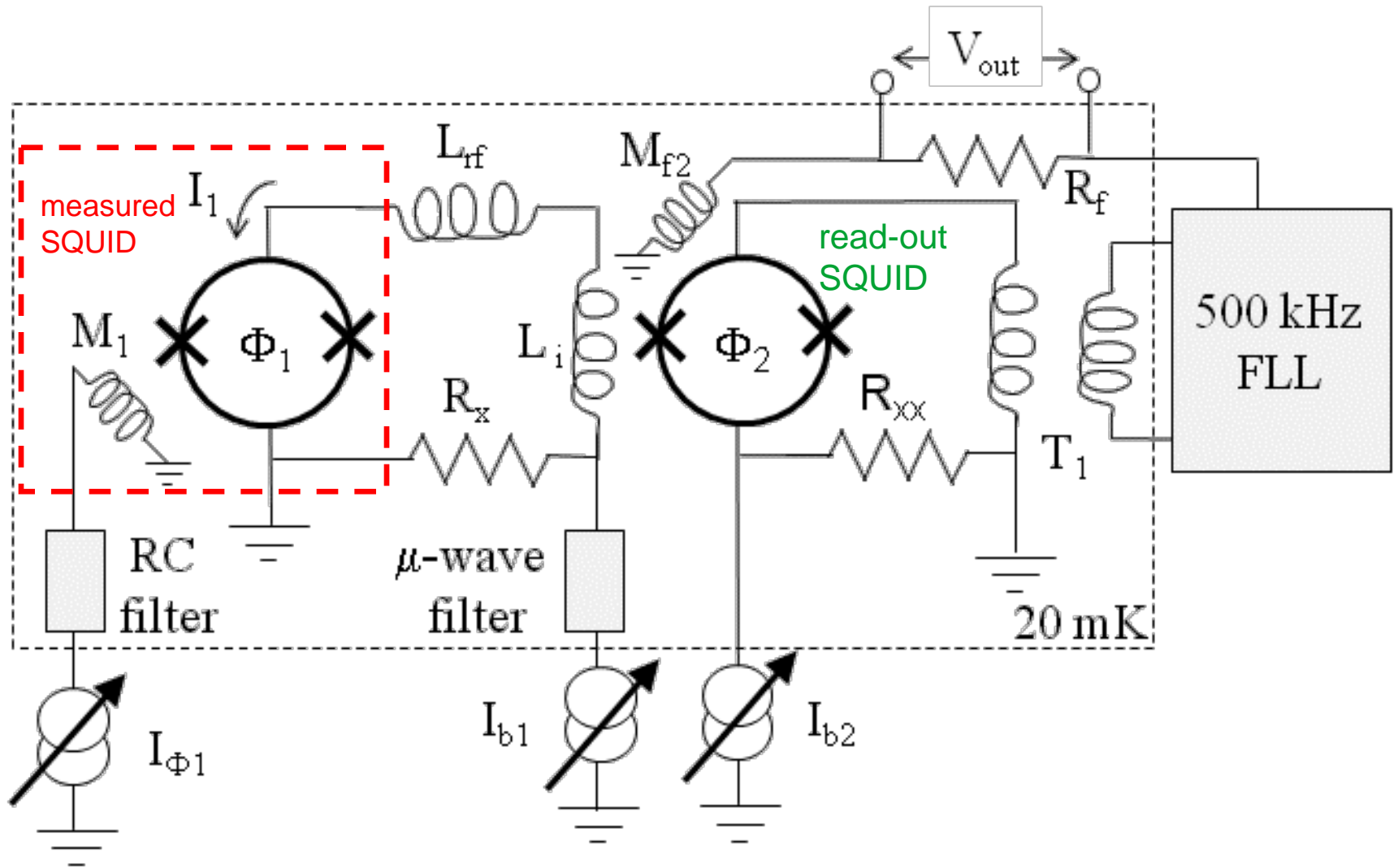

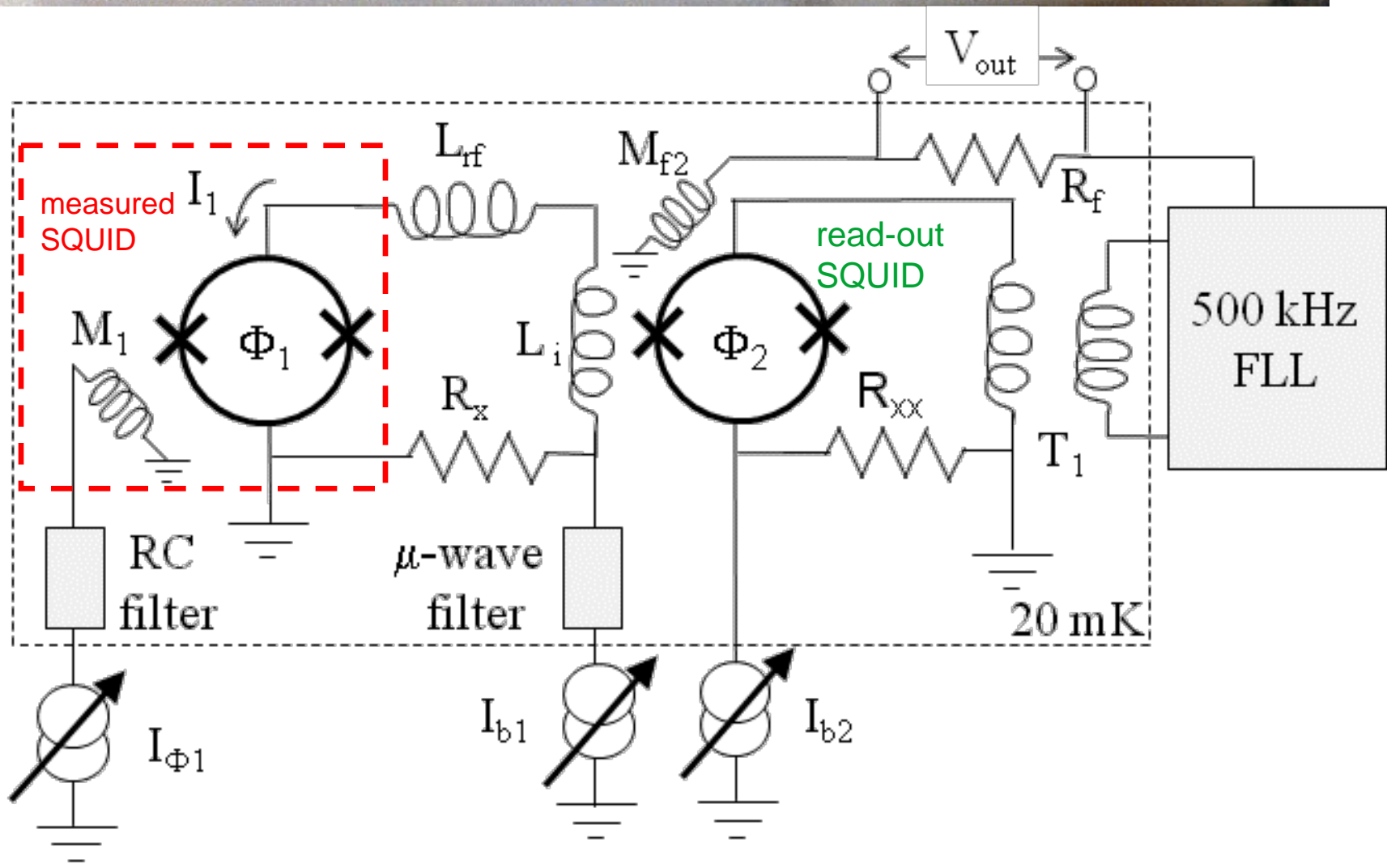

Flux noise measurement technique

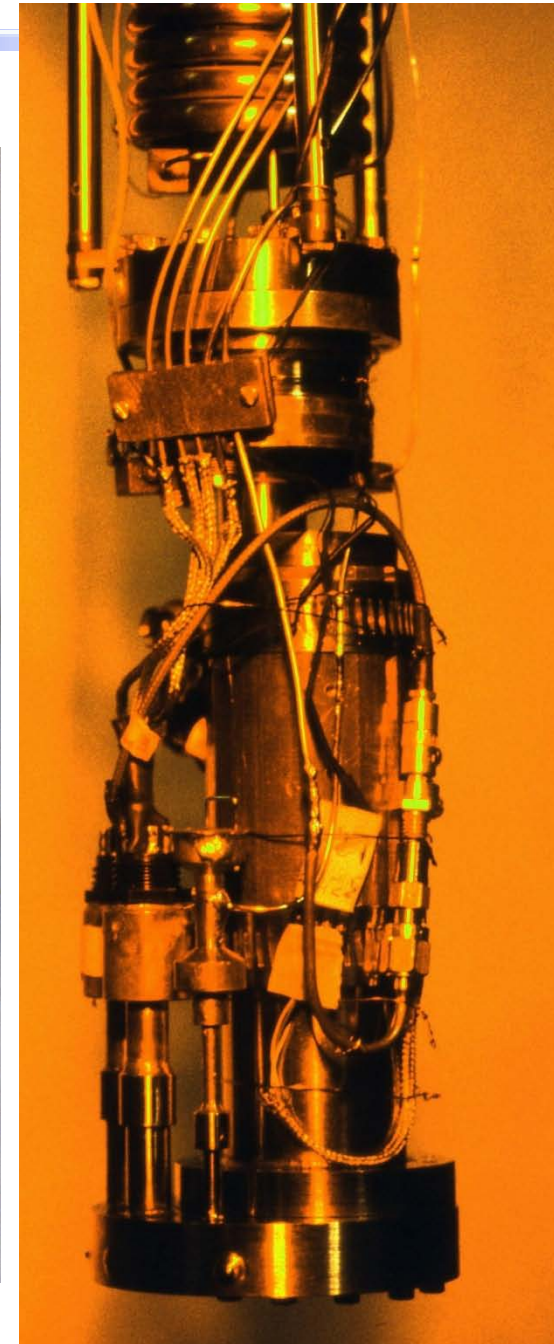
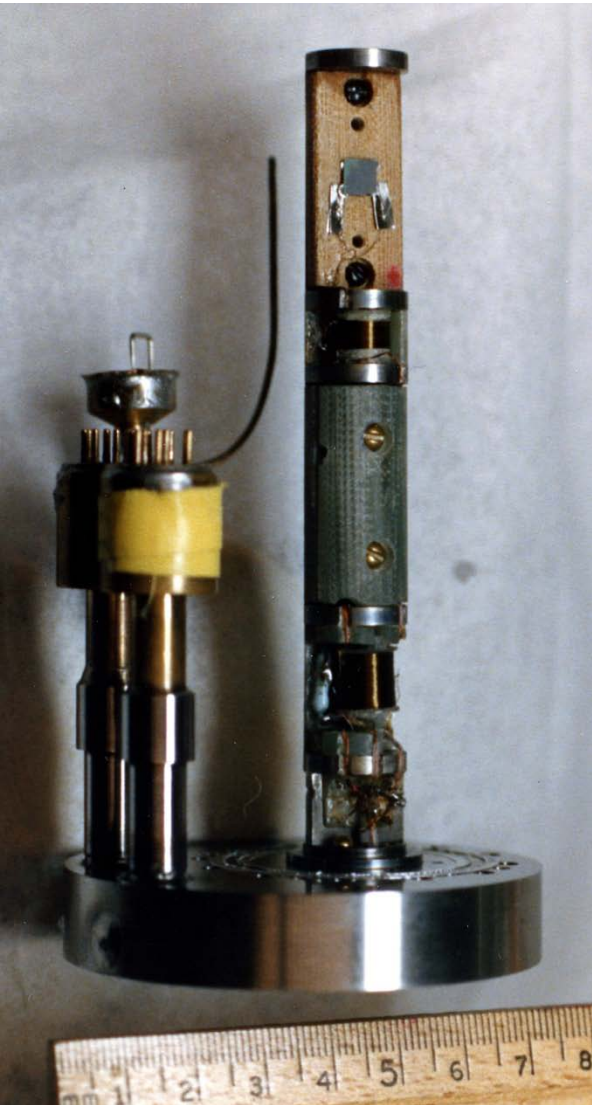

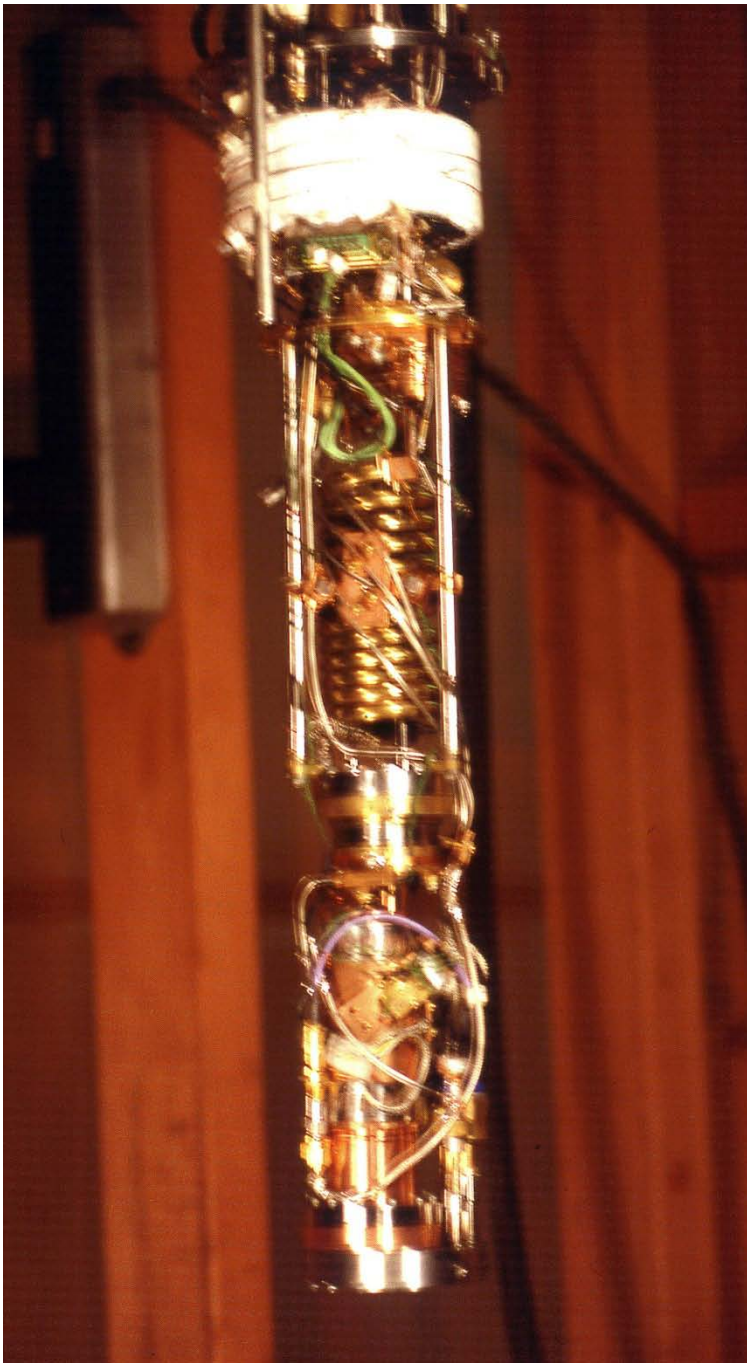

Surround cell with:

Vacuum can

aluminum dewar

2 mu-metal cylinders

cu-mesh shielded room

in second basement lab

Cell filled with liquid helium

Measurements made from 4.2 K to 0.02 K,

on shunted SQUIDs in the continuously
running state (Power \sim few pW),

in low-field,

in '84-87



Clarke's dilution refrigerator lab - Second Basement of Birge Hall ~1985

Nb/NbO_x/PbIn SQUID

Type D

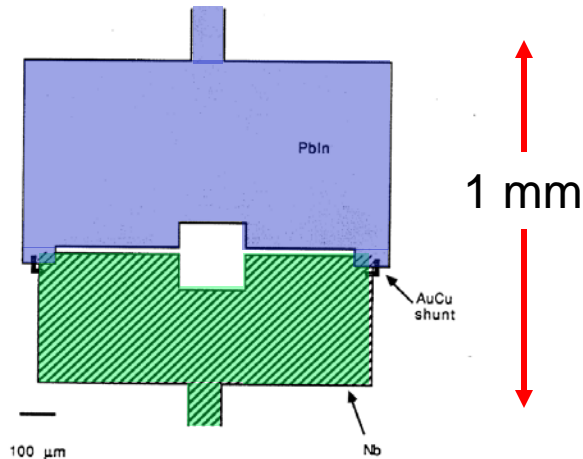

Typical Fabrication Procedure:

- 1) Clean 2" wafer (Si, Oxidized Si, or sapphire), pattern photoresist, deposit Cr or Ti and then AuCu, liftoff in acetone
- 2) clean, sputter Nb
pattern photoresist
plasma etch in SF₆O₂
- 3) clean, pattern photoresist
deposit Cr or Ti and then SiO₂,
liftoff in acetone
- 4) clean, pattern photoresist
deposit Cr or Ti and then SiO₂
liftoff in acetone
- 5) clean, pattern photoresist
- 6) Dice wafer into 5 mm chips
- 7) Use Ar-Ion mill to clean Nb surface,
transfer chip in air to oxidation chamber,
oxidize in Ar+O₂ plasma
evaporate Pb+ 5%In
liftoff in acetone

Flux noise spectrum: SQUID D2

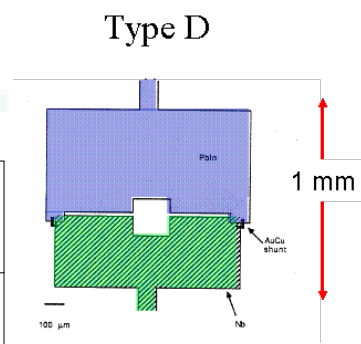
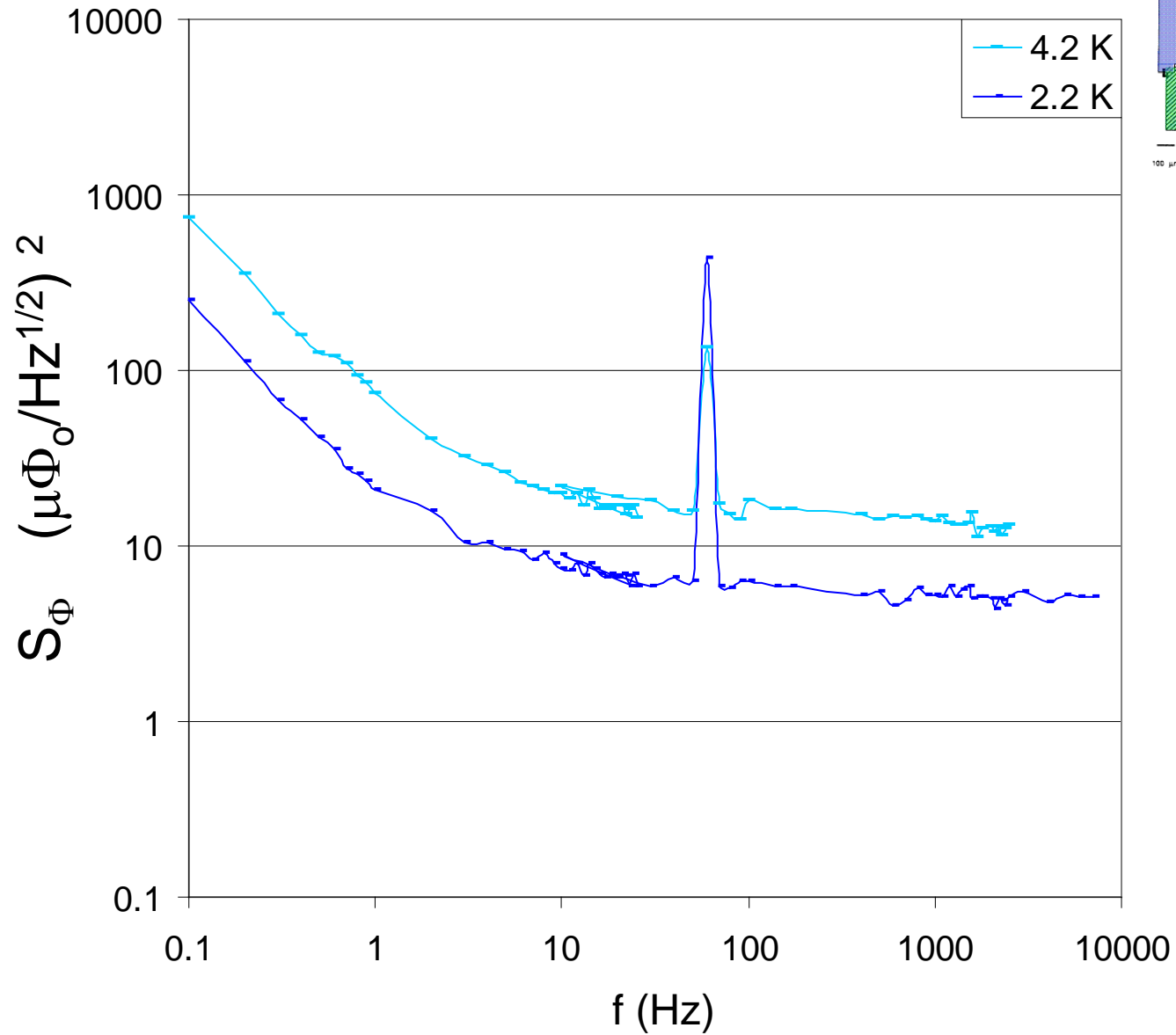

Flux noise spectrum: SQUID D2

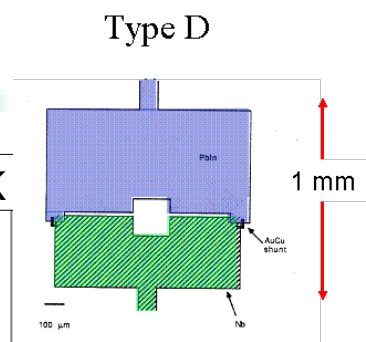
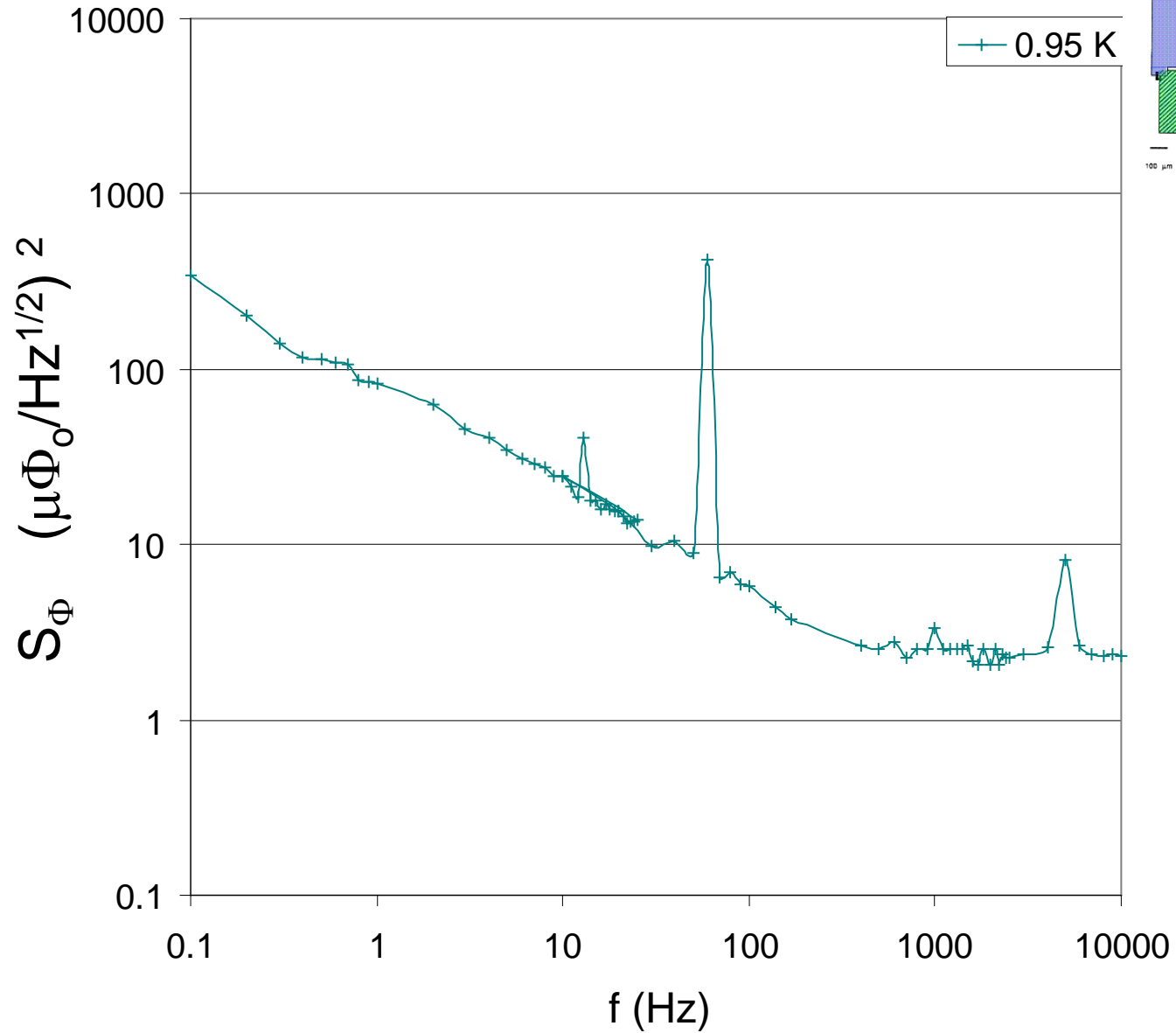

Flux noise spectrum: SQUID D2

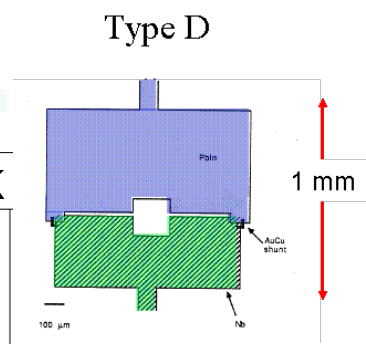
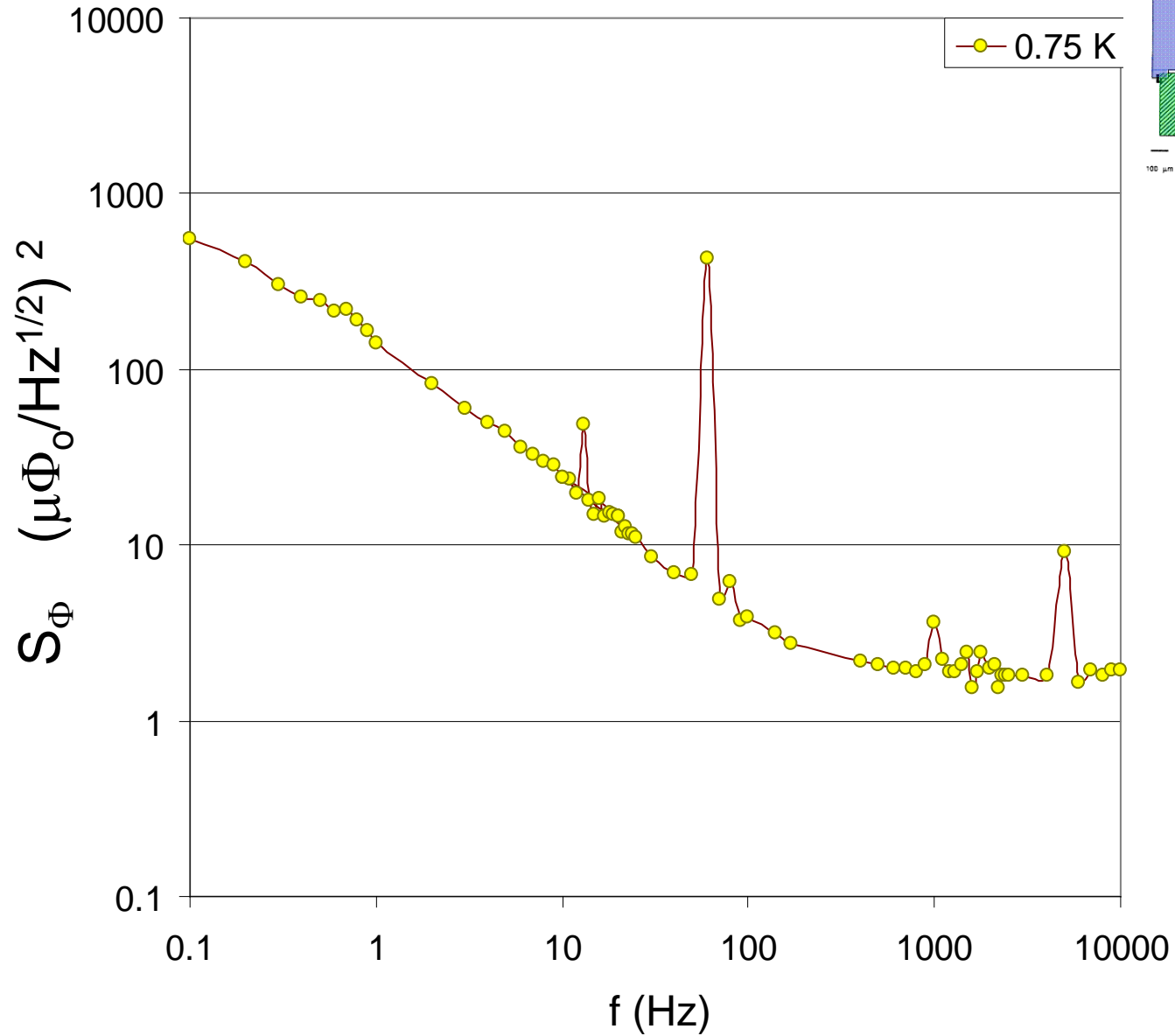

Flux noise spectrum: SQUID D2

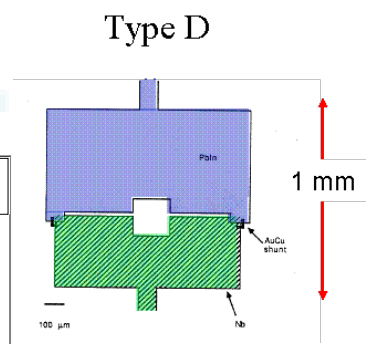
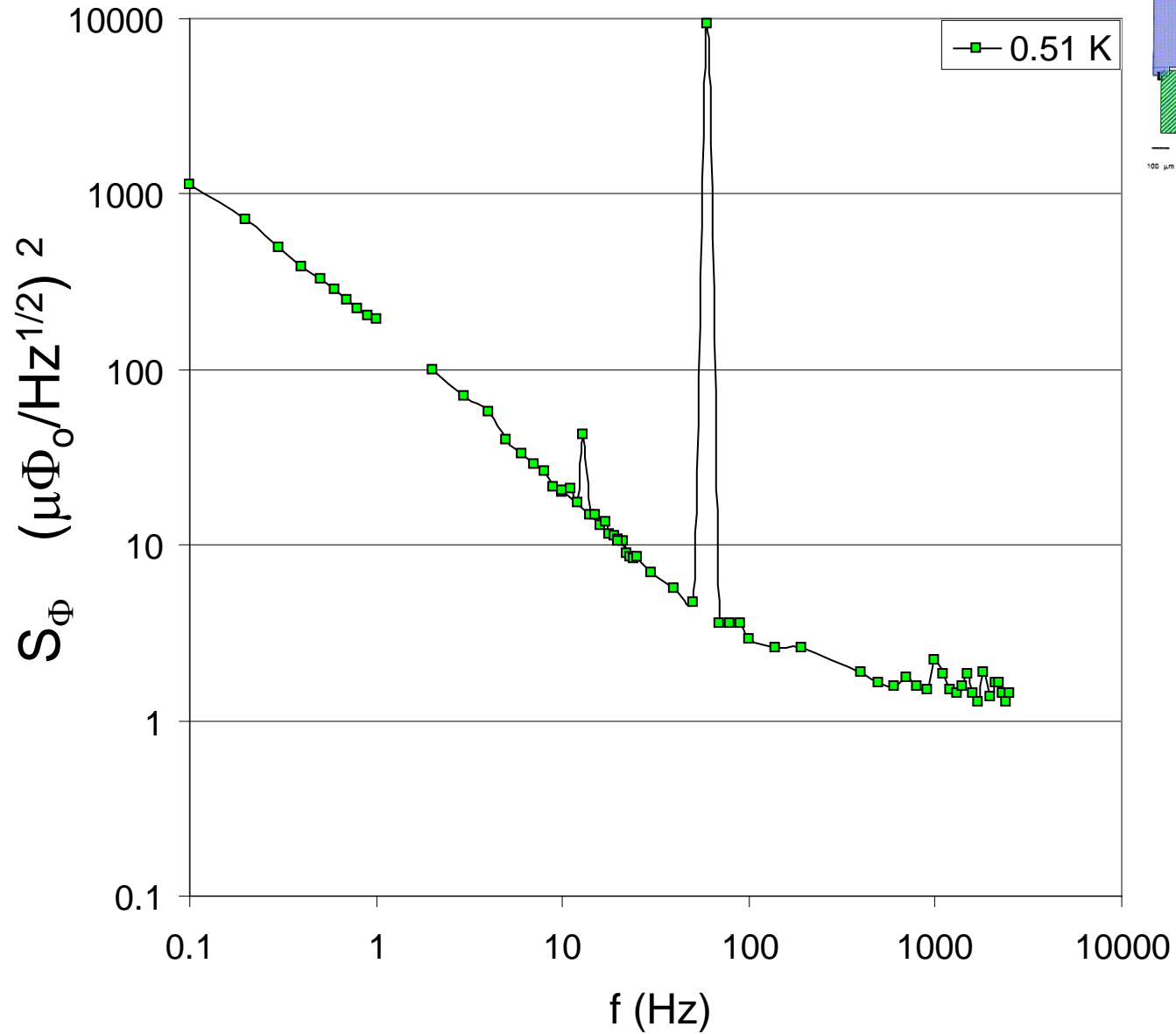

Flux noise spectrum: SQUID D2

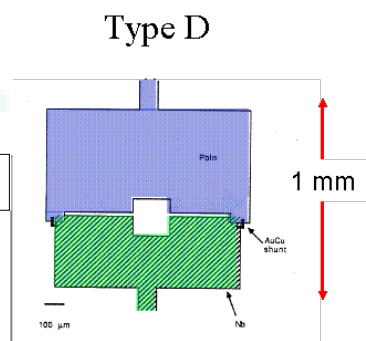
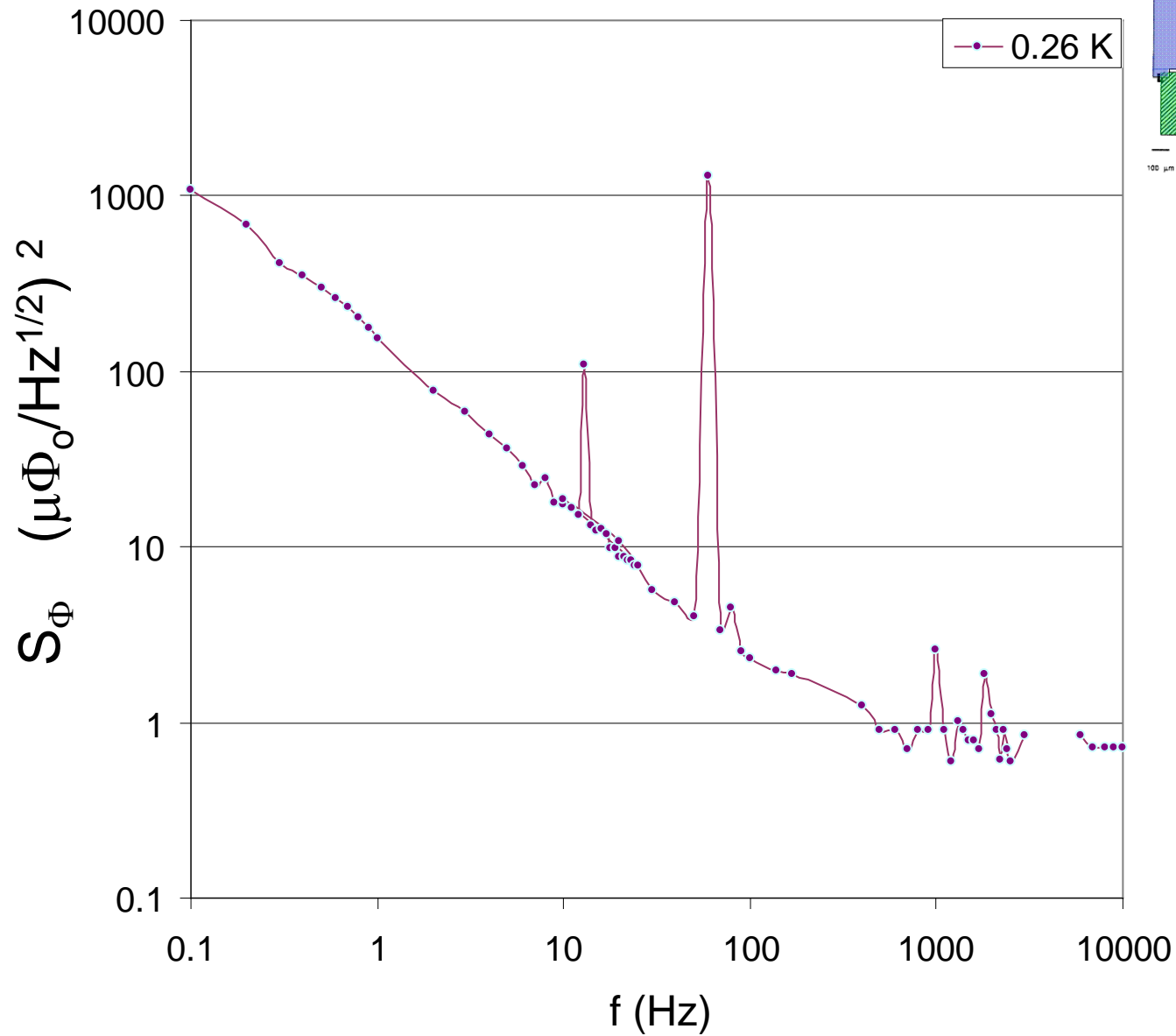

Flux noise spectrum: SQUID D2

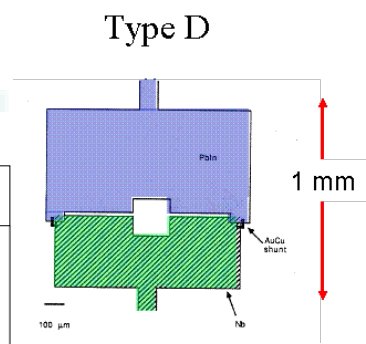
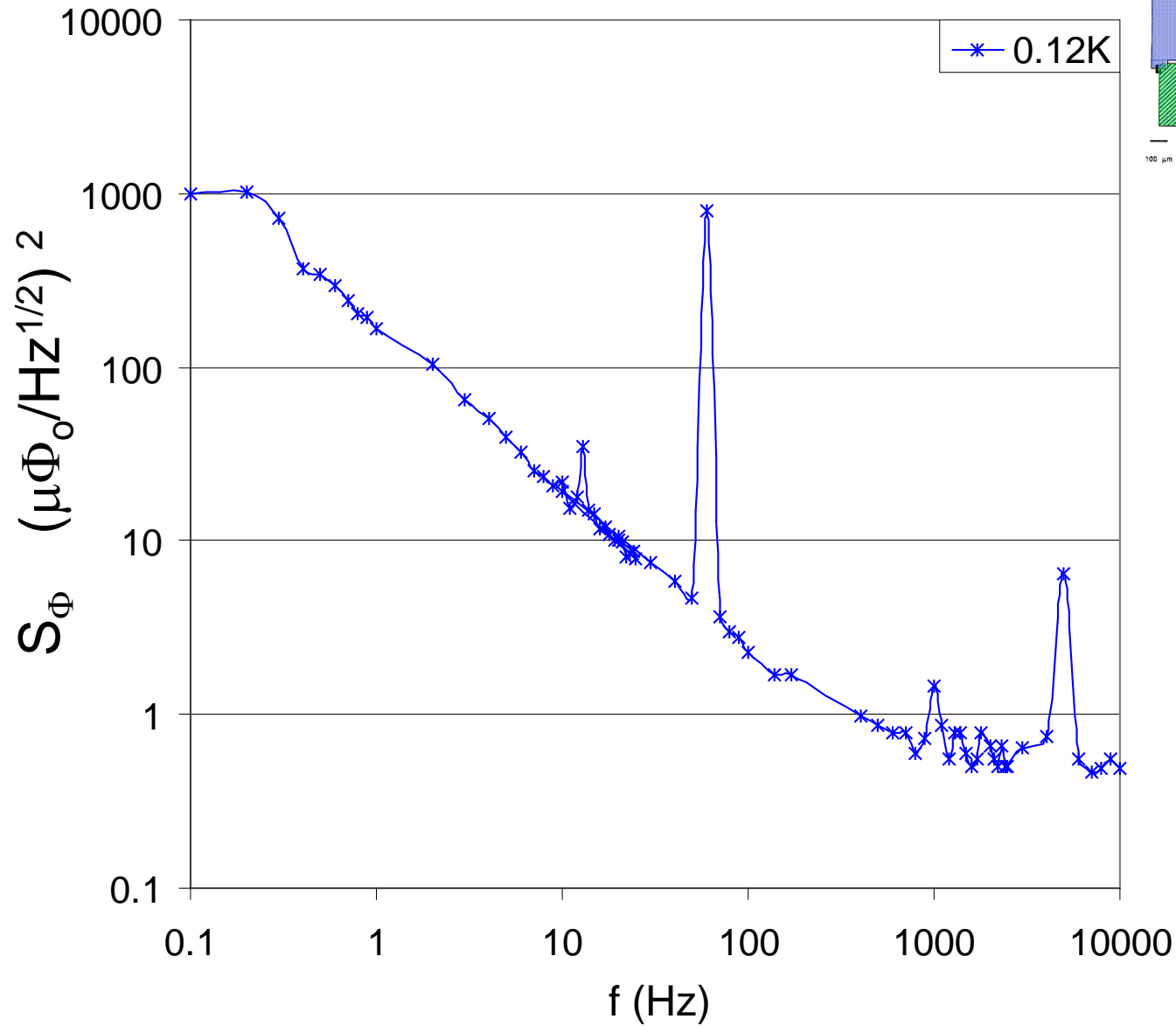

Flux noise spectrum: SQUID D2

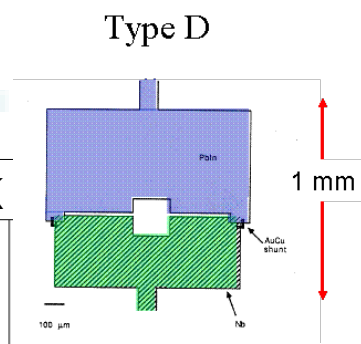
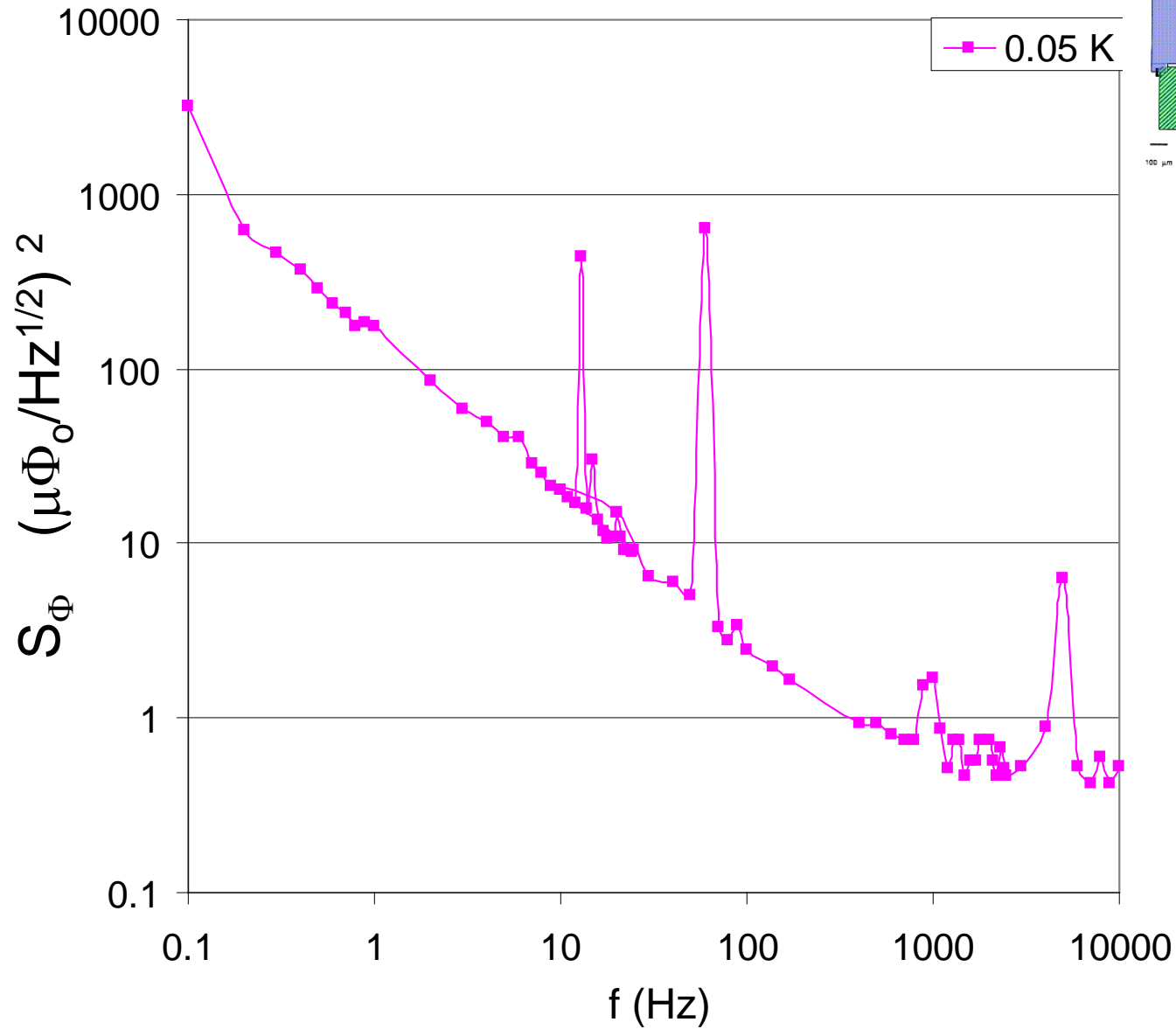

Flux noise spectrum: SQUID D2

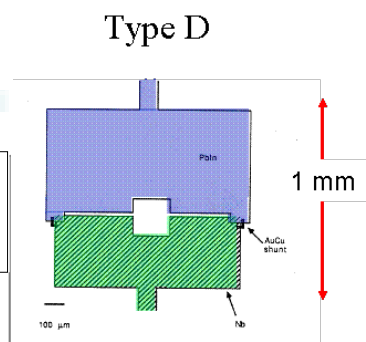
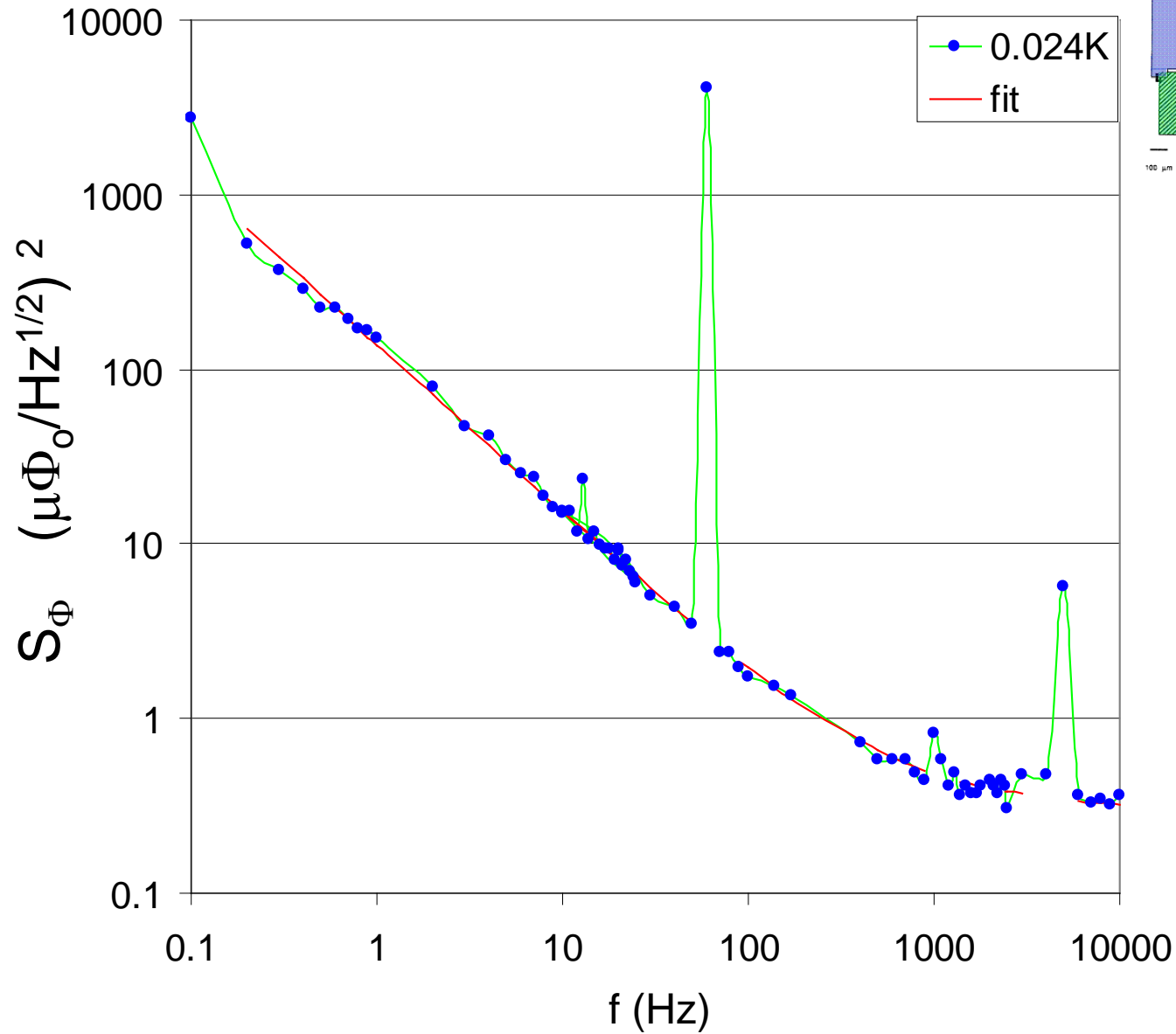

Flux noise spectrum: SQUID D2

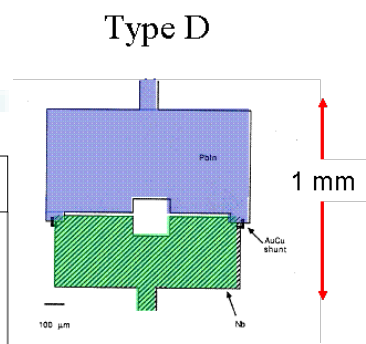
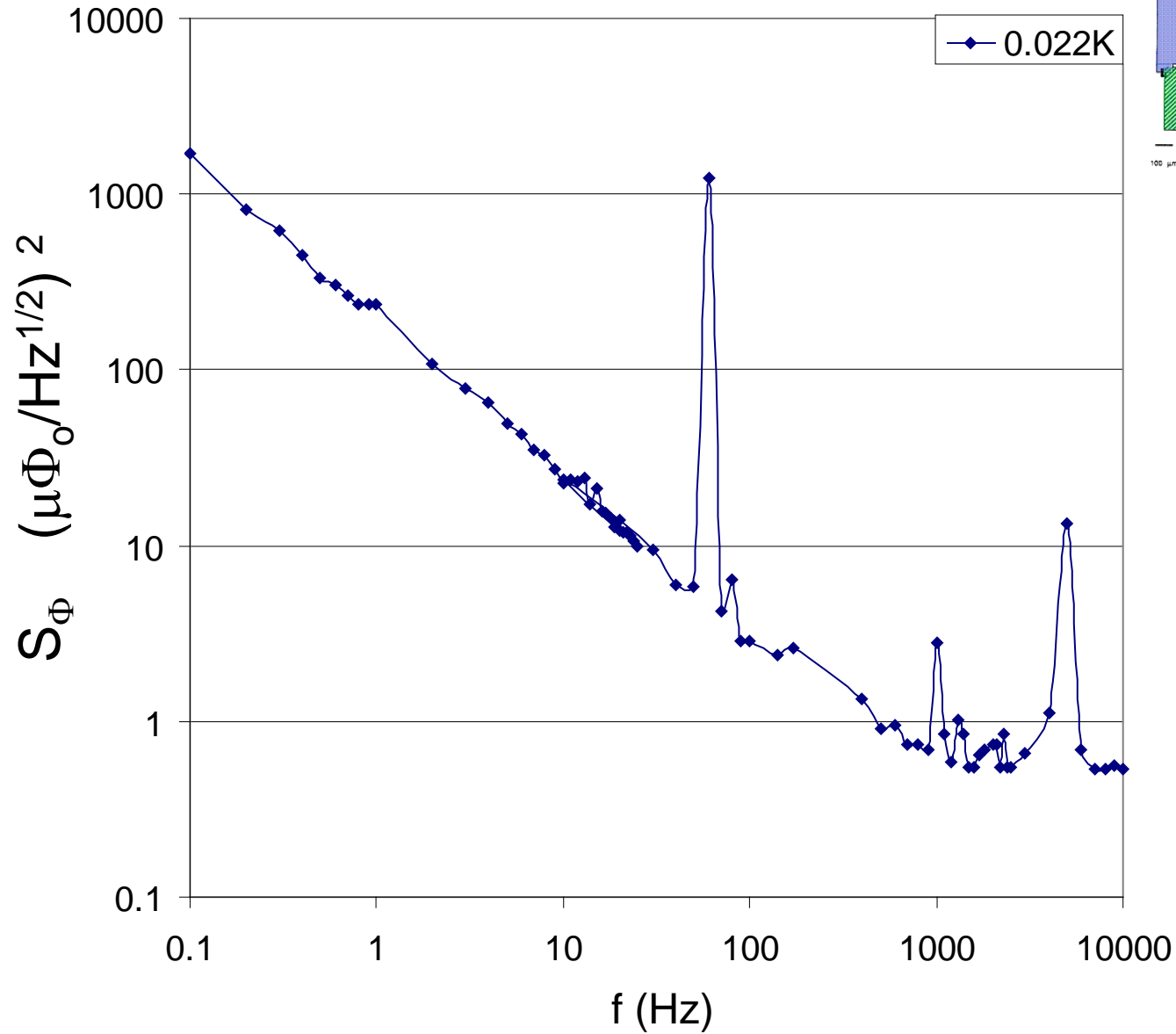

Flux noise spectrum: SQUID D2

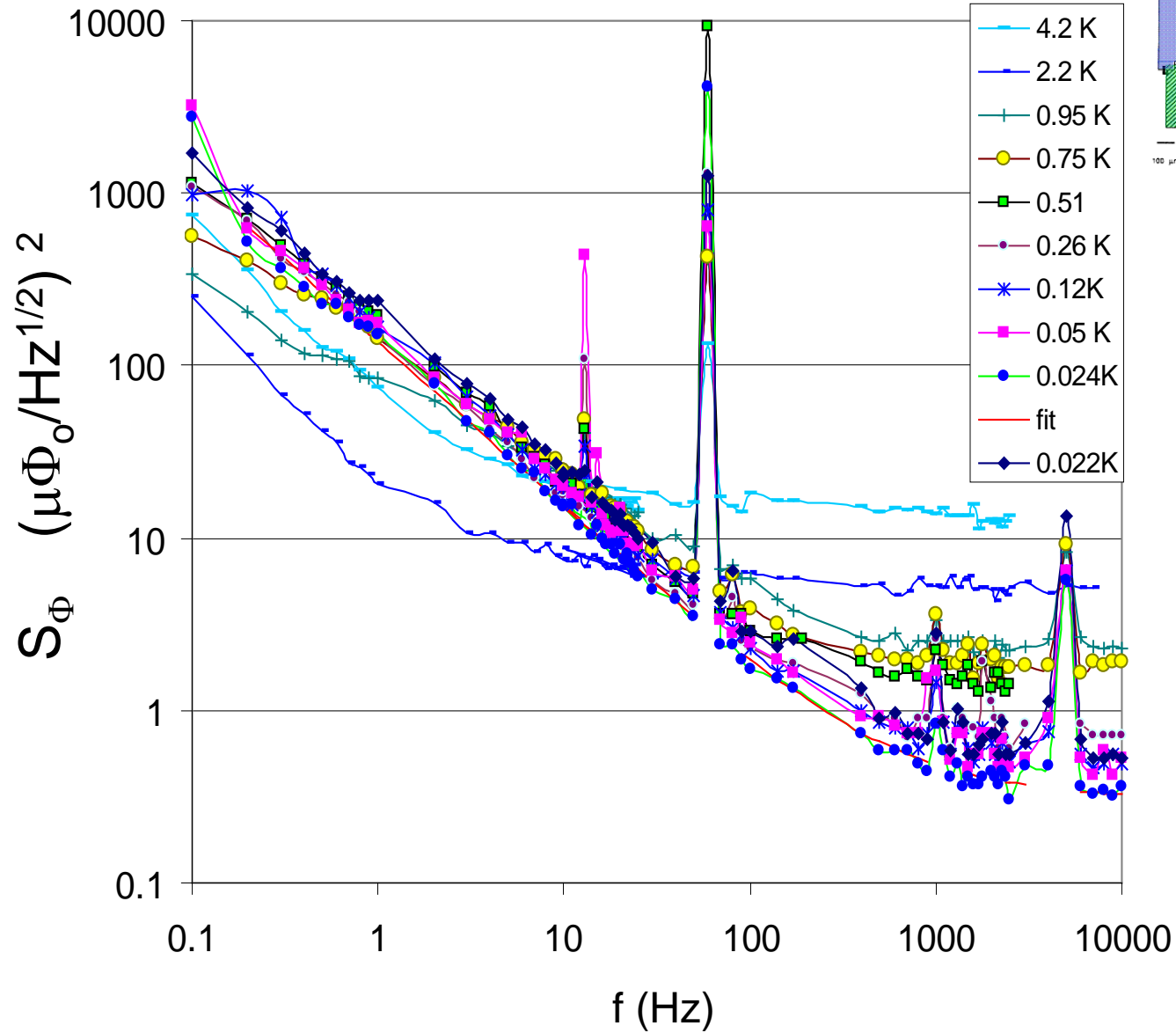

Type D

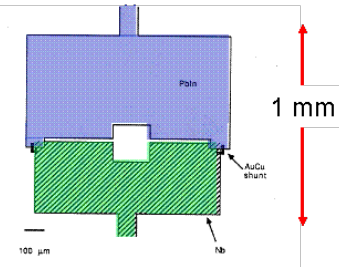

RMS flux noise power spectral density at 1Hz vs T in device D2

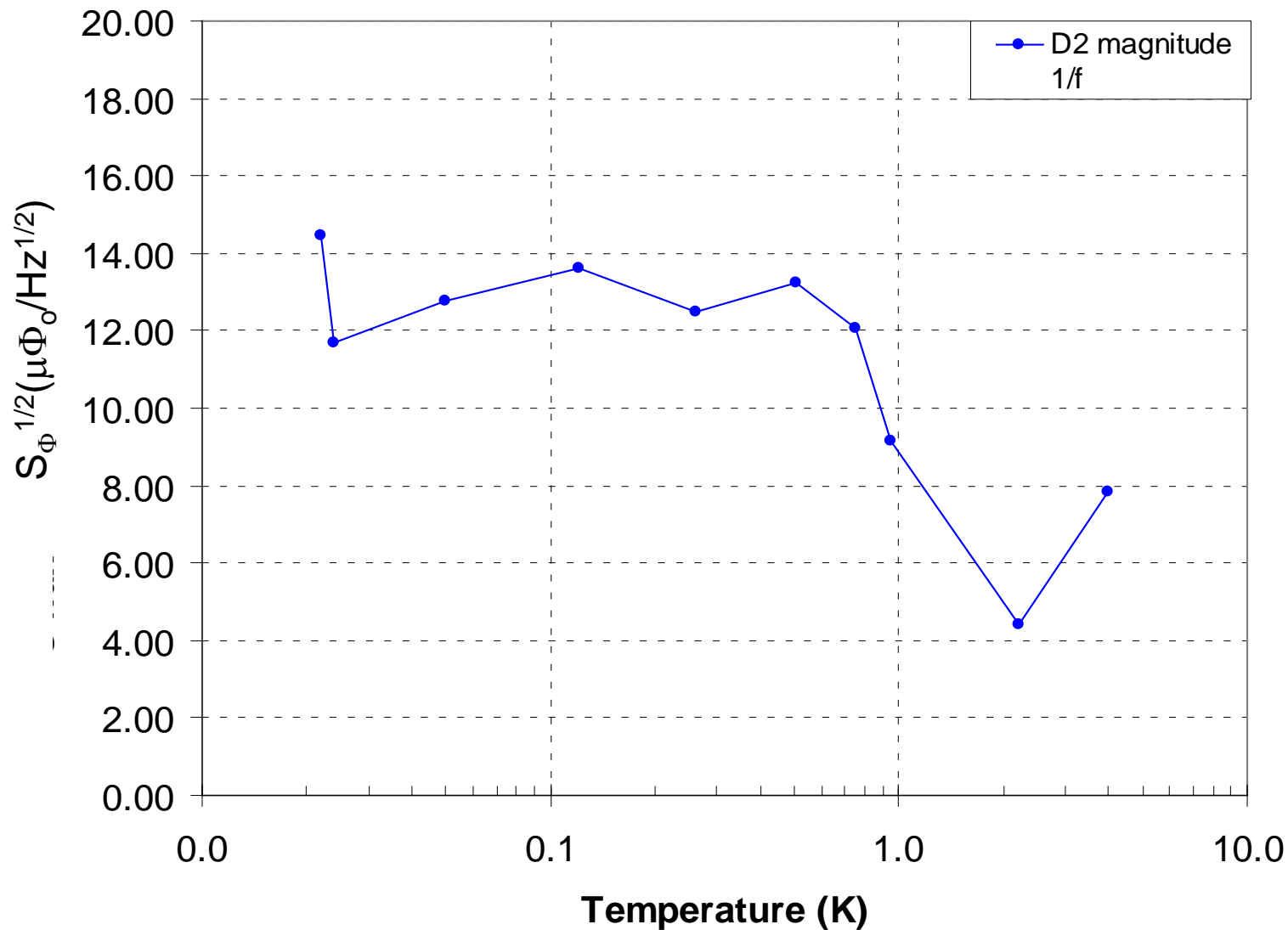

Type D

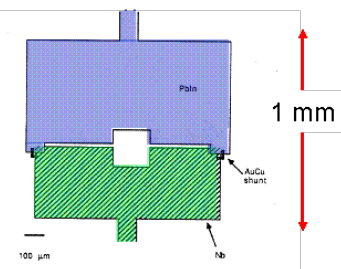

"Big" SQUIDs

Type D

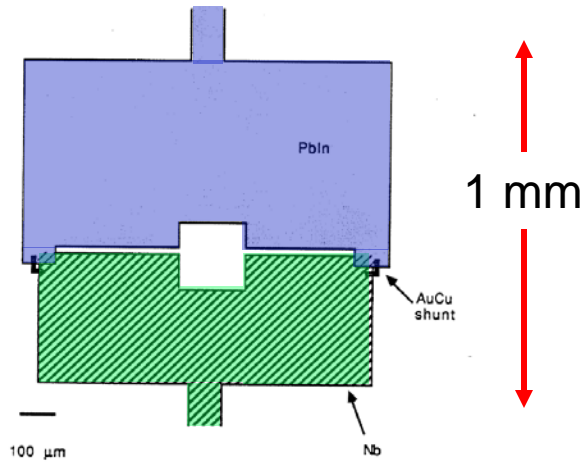

Type M

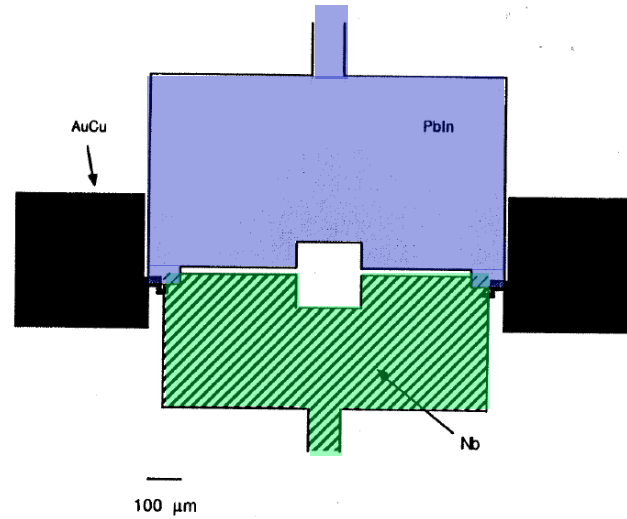
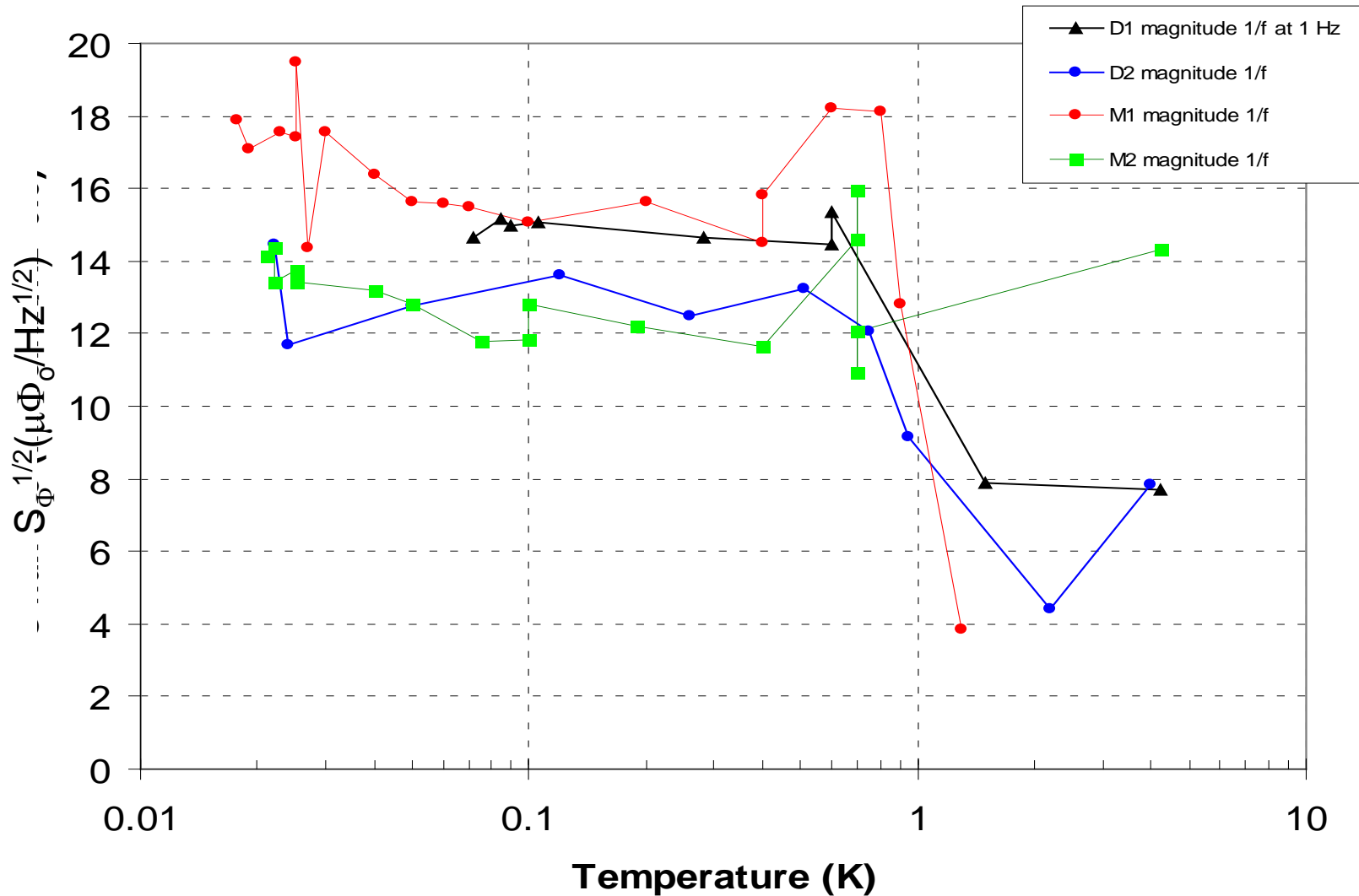

Fig. 1.16 Schematic of a Type M dc SQUID.

RMS flux noise power spectral density at 1Hz vs T



- noise magnitude **increases** as T **decreases** below 1 K
- different devices with same shape produce similar noise

"Big" SQUIDs

Type D

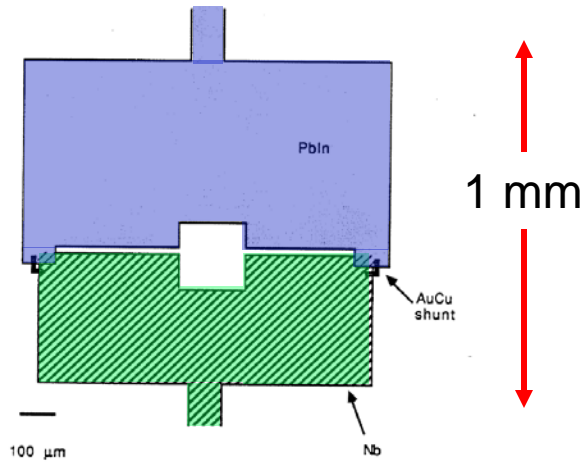

Type M

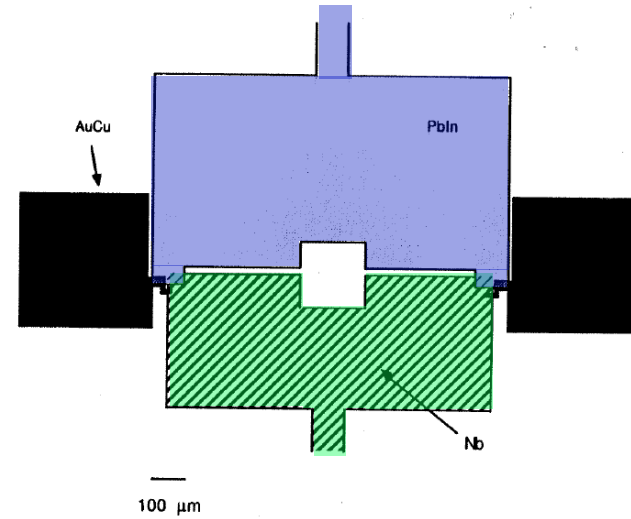
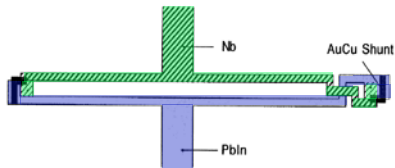

Fig. 1.16 Schematic of a Type M dc SQUID.

Type K



built on sapphire

Type P



Type P

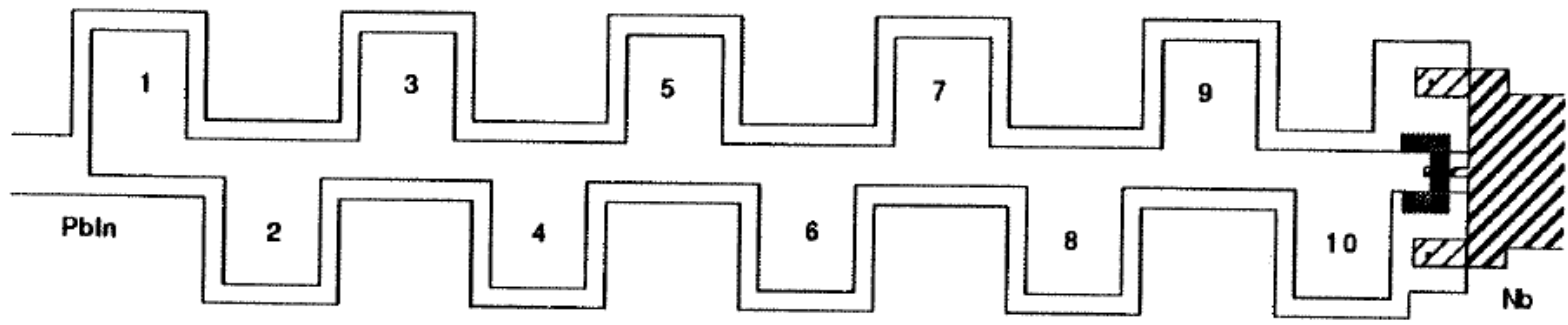
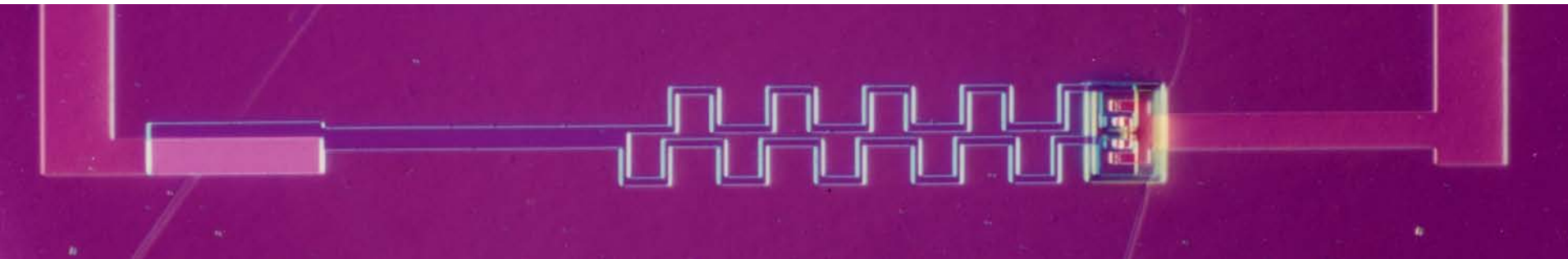

100 μm

RMS flux noise power spectral density at 1Hz vs T

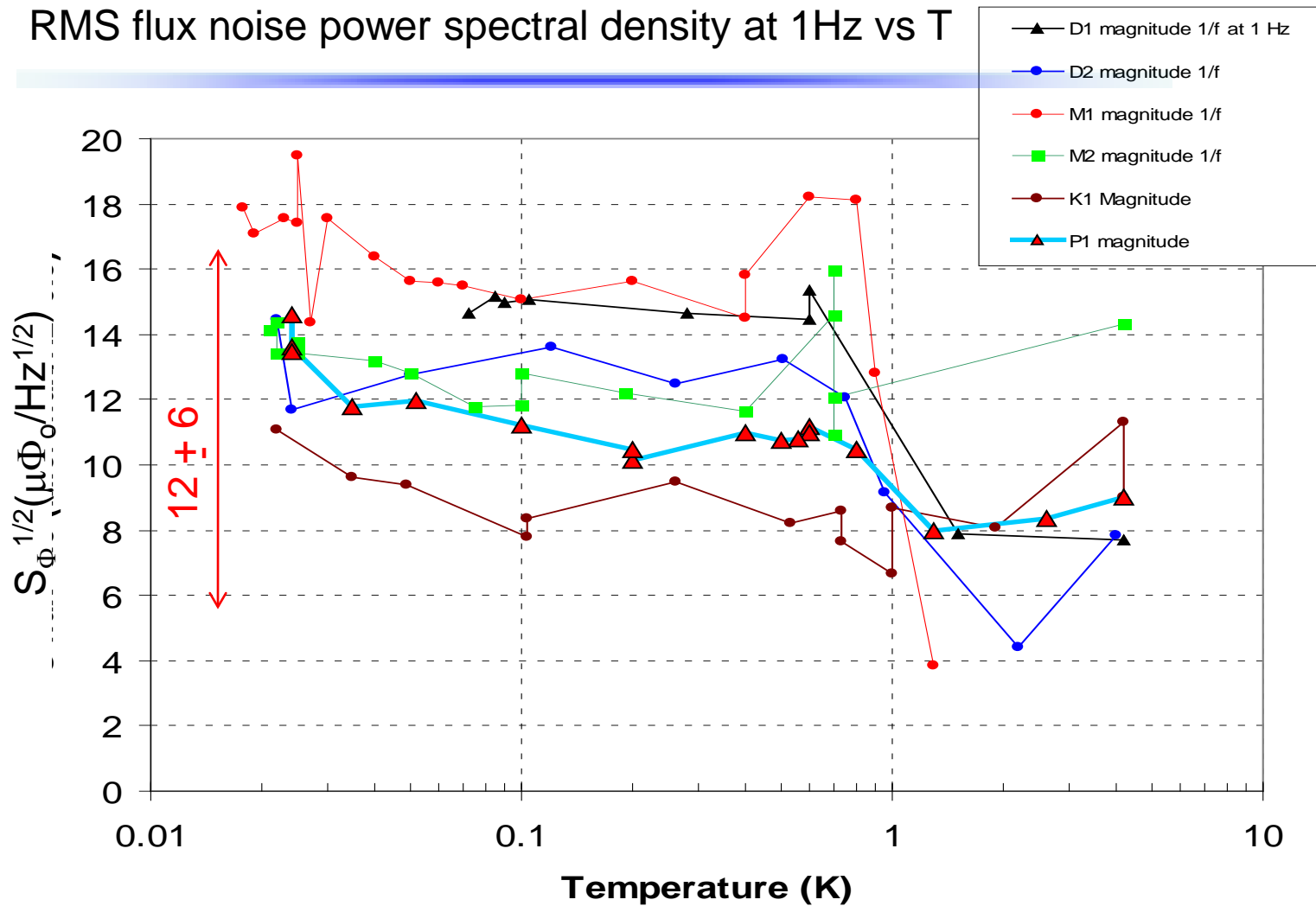

- noise magnitude **increases** as T **decreases** below 1 K
- different devices with same shape produce similar noise
- noise depends weakly on SQUID "size" (linewidth ? overall length?)
- noise present with sapphire or Si substrates

"Small" SQUIDs

Type C

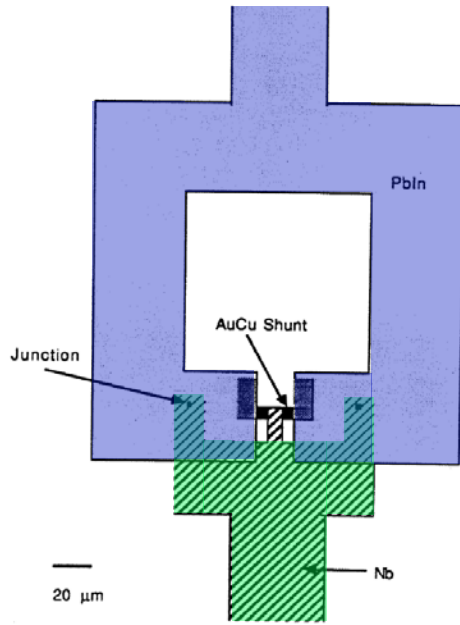
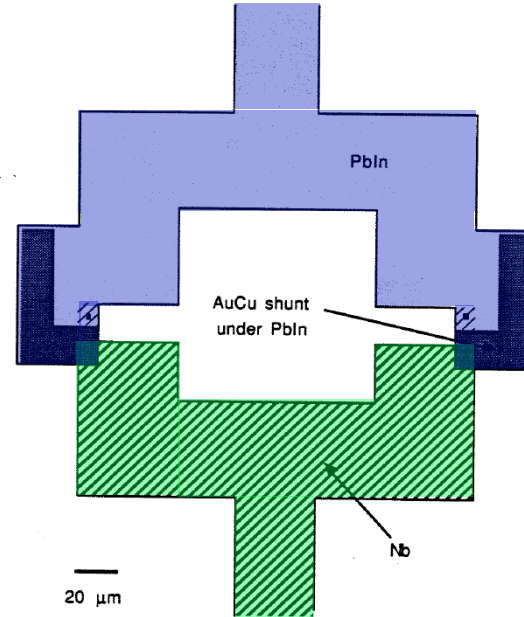

Fig. 1.7 Schematic of a Type C dc SQUID.



Type J
built on
sapphire

Fig. 1.13 Schematic of a Type J dc SQUID.

Type O

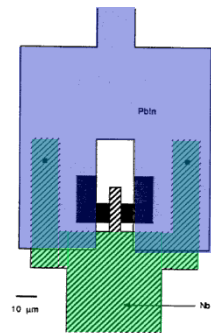

Fig. 1.18 Schematic of a Type O dc SQUID.

100 μm

Type F

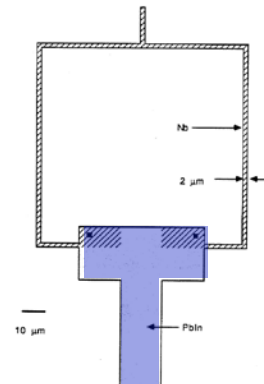
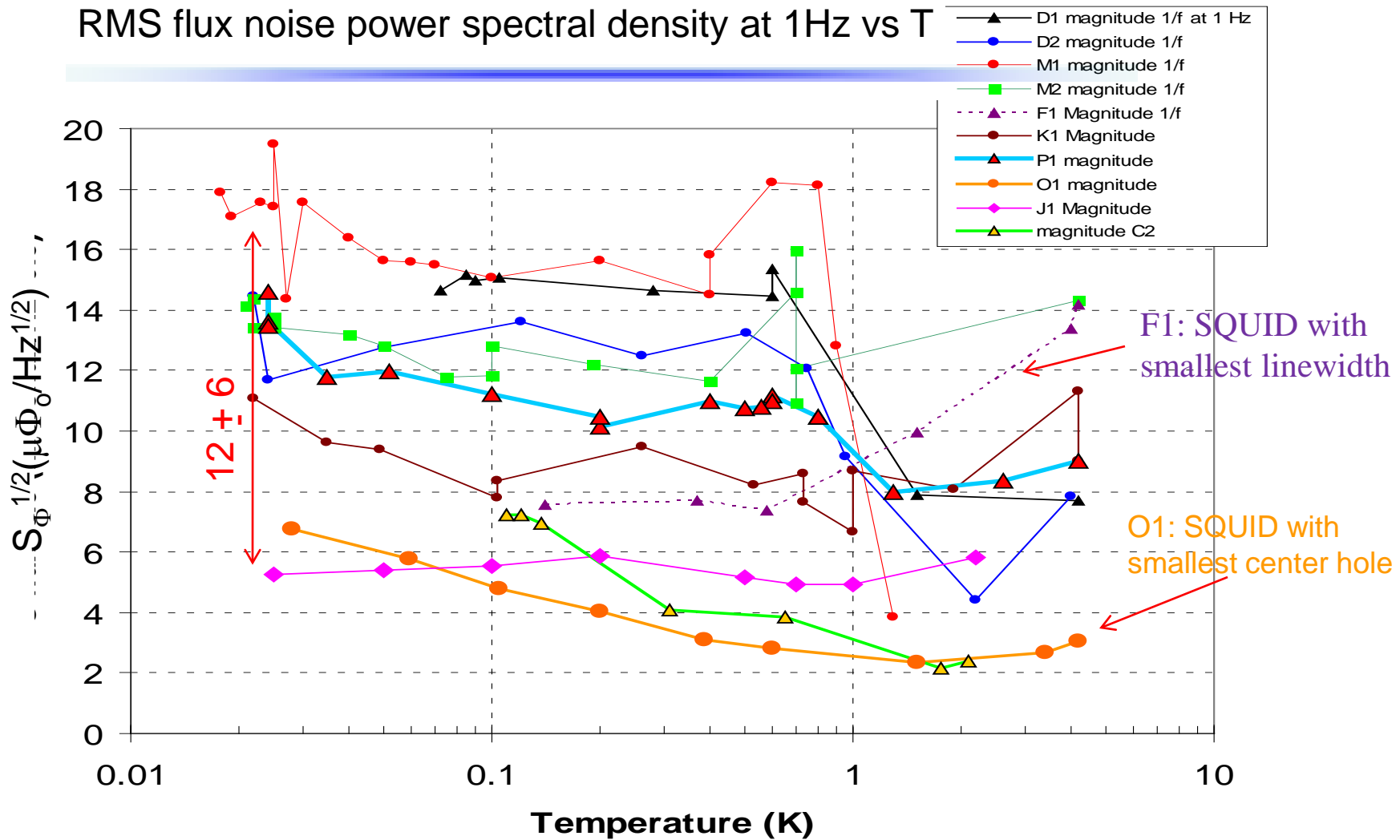

Fig. 1.10 Schematic of a Type F dc SQUID.

RMS flux noise power spectral density at 1Hz vs T



- noise magnitude **increases** as T **decreases** below 1 K
- different devices with same shape produce similar noise
- noise depends weakly on size of SQUID center hole
- noise independent of materials & substrate (Si, sapphire, oxidized Si)

Flux noise power and magnetic loss tangent

■ Fluctuation-dissipation theorem:

when there is noise there is an associated dissipation

■ For magnetic dissipation in a loop, we can define a complex permeability $\mu = \mu_1 - i\mu_2$ and a complex inductance

$$L_c = (\mu_1 - i\mu_2)\mu_o F(a, b, \dots)$$

■ The impedance of the loop is:

$$\begin{aligned} Z(\omega) &= i\omega L_c = i\omega(\mu_1 - i\mu_2)\mu_o F(a, b, \dots) = i\omega\mu_1\mu_o F(a, b, \dots) \left(1 - i\frac{\mu_2}{\mu_1}\right) \\ &= i\omega L \left(1 - i\frac{\mu_2}{\mu_1}\right) = i\omega L + \omega L \tan(\delta_m) = i\omega L + R_m(\omega) \end{aligned}$$

■ The flux noise produced in the loop is then:

$$S_\Phi(f) = S_I(f)L^2 = \frac{S_v(f)L^2}{\omega^2 L^2 + R_m^2} = \frac{4k_B T L^2 \cdot \text{Im}(Z(\omega))}{\omega^2 L^2 + \omega^2 L^2 \tan^2(\delta_m)} = \frac{4k_B T L^2 \cdot \omega L \tan(\delta_m)}{\omega^2 L^2 + \omega^2 L^2 \tan^2(\delta_m)}$$

Flux noise power and magnetic loss tangent

For $\tan(\delta_m) \ll 1$, we find

$$S_\Phi(f) \cong \frac{4k_B T L}{2\pi f} \tan(\delta_m)$$



$$\tan(\delta_m) \cong \frac{\pi f S_\Phi(f)}{2k_B T L}$$

If $\tan(\delta_m)$ is independent of frequency, then we get $1/f^1$ noise,
If flux noise independent of T, then $\tan(\delta)$ scales as $1/T$.

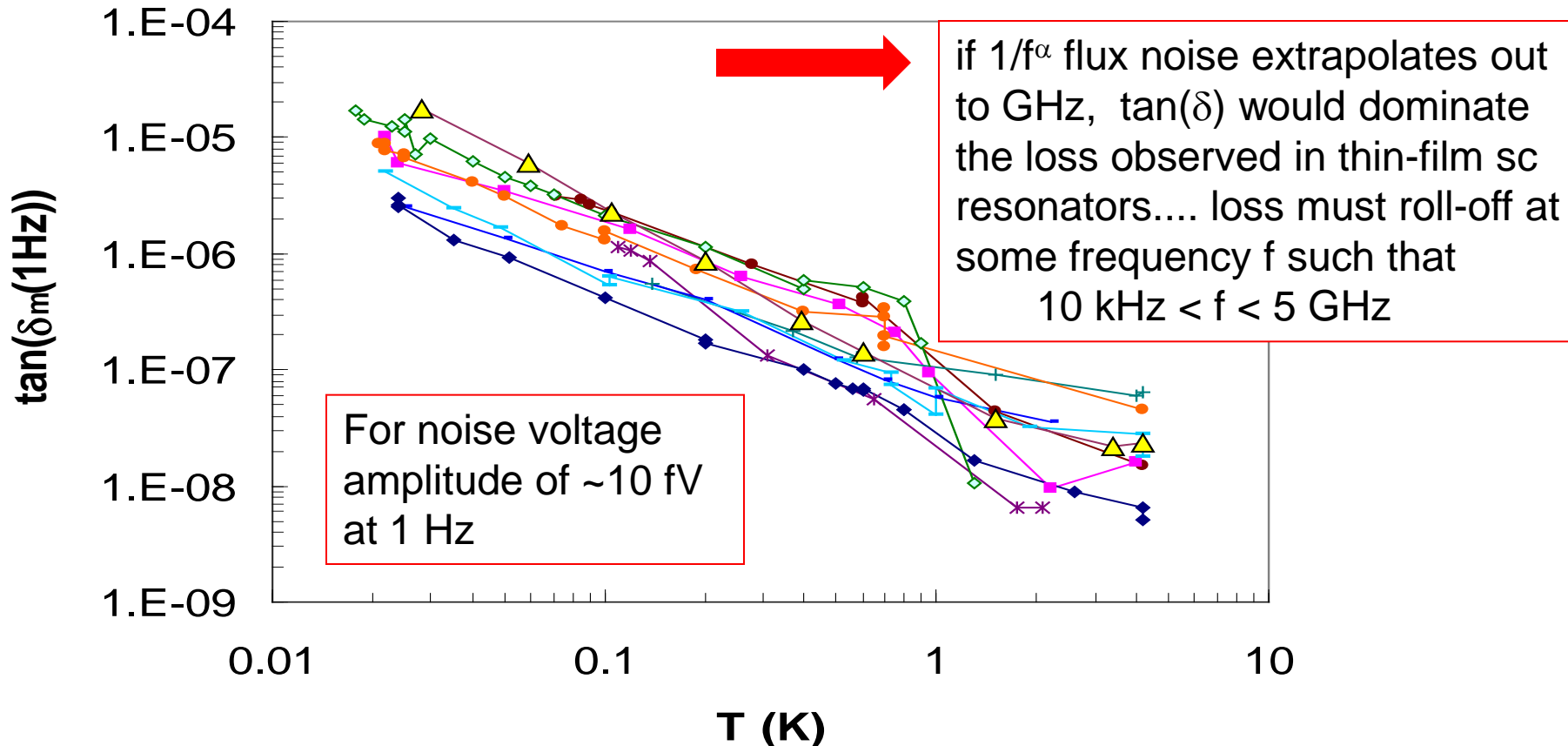

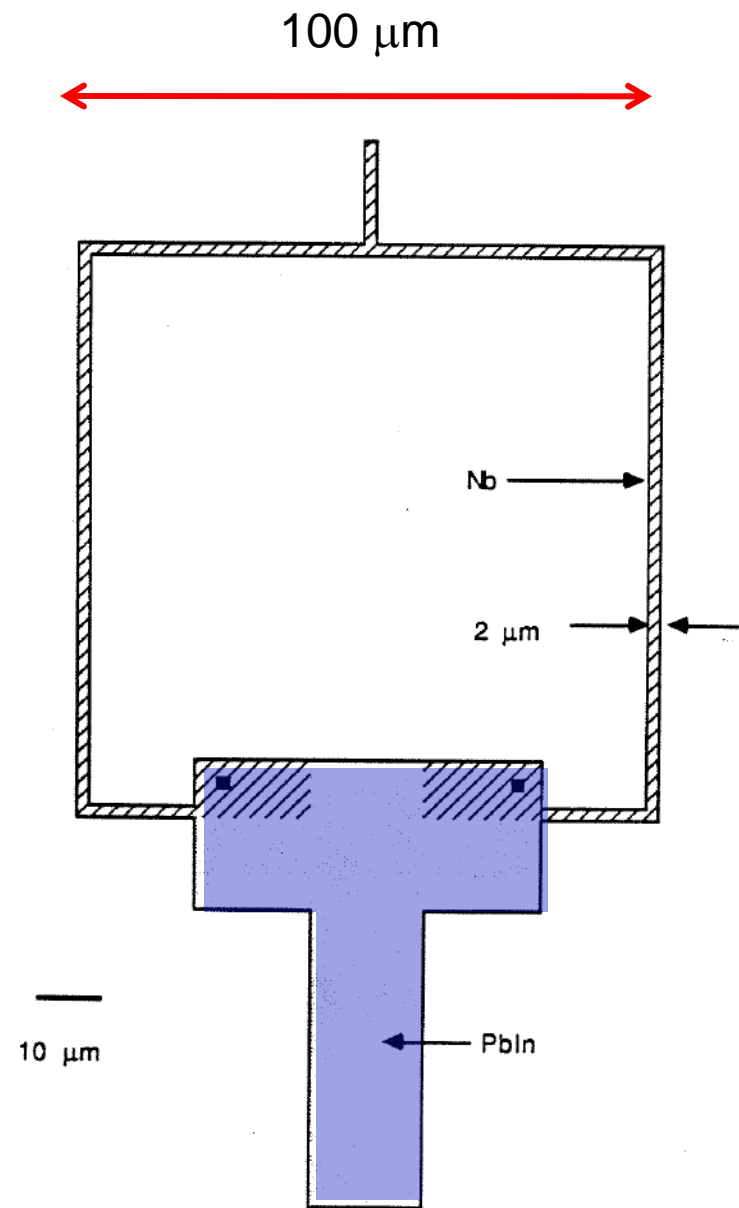
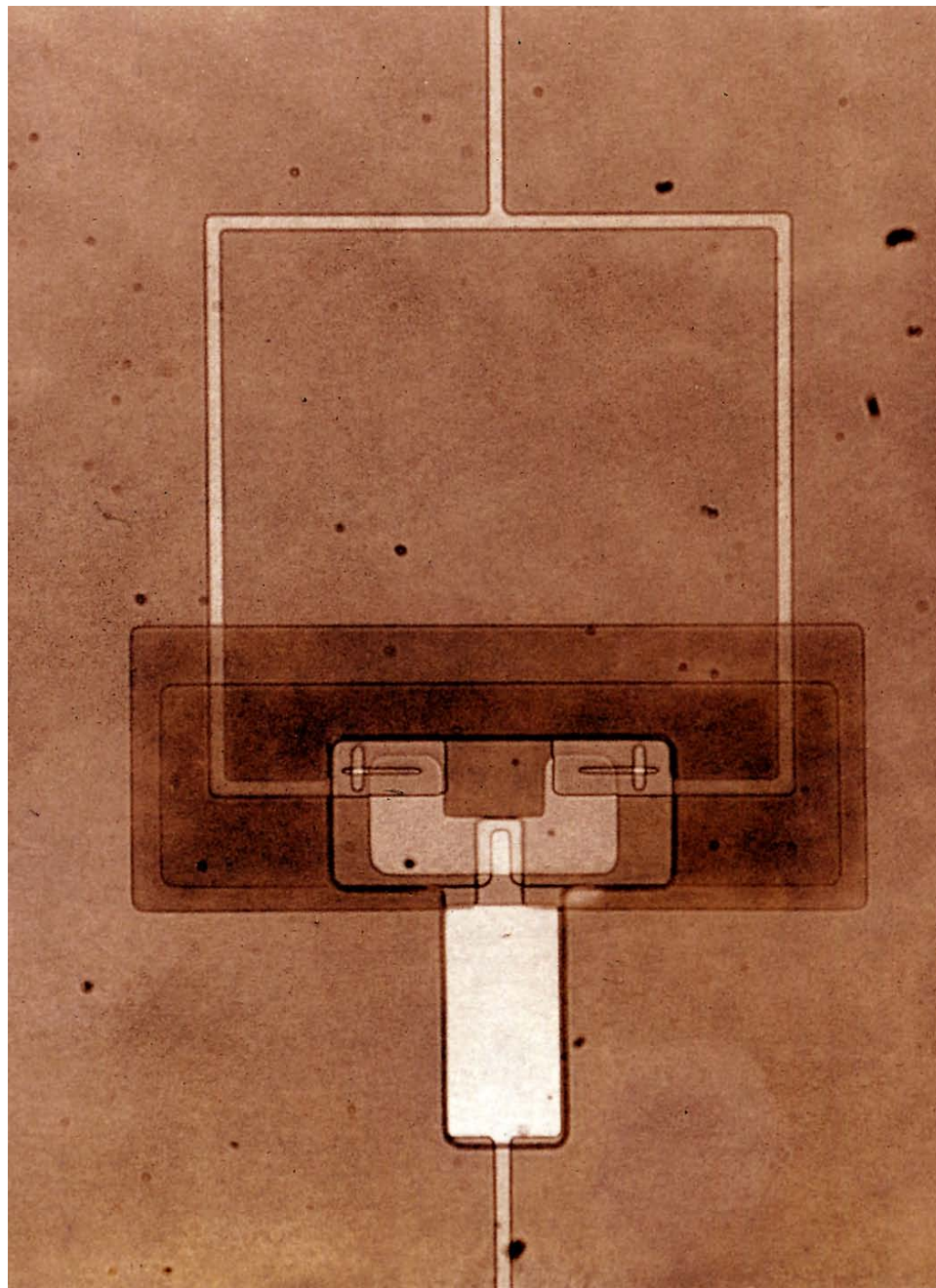
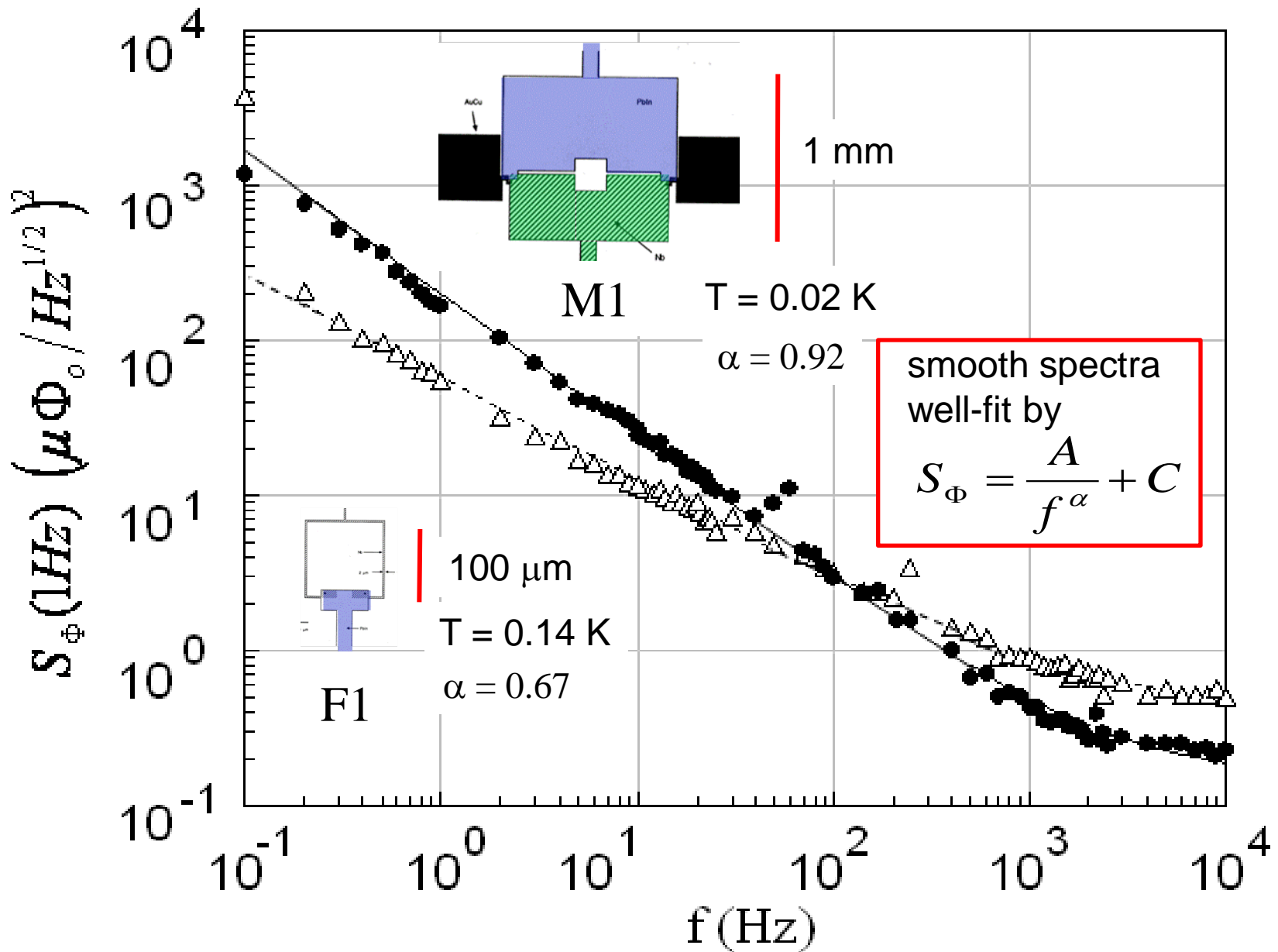
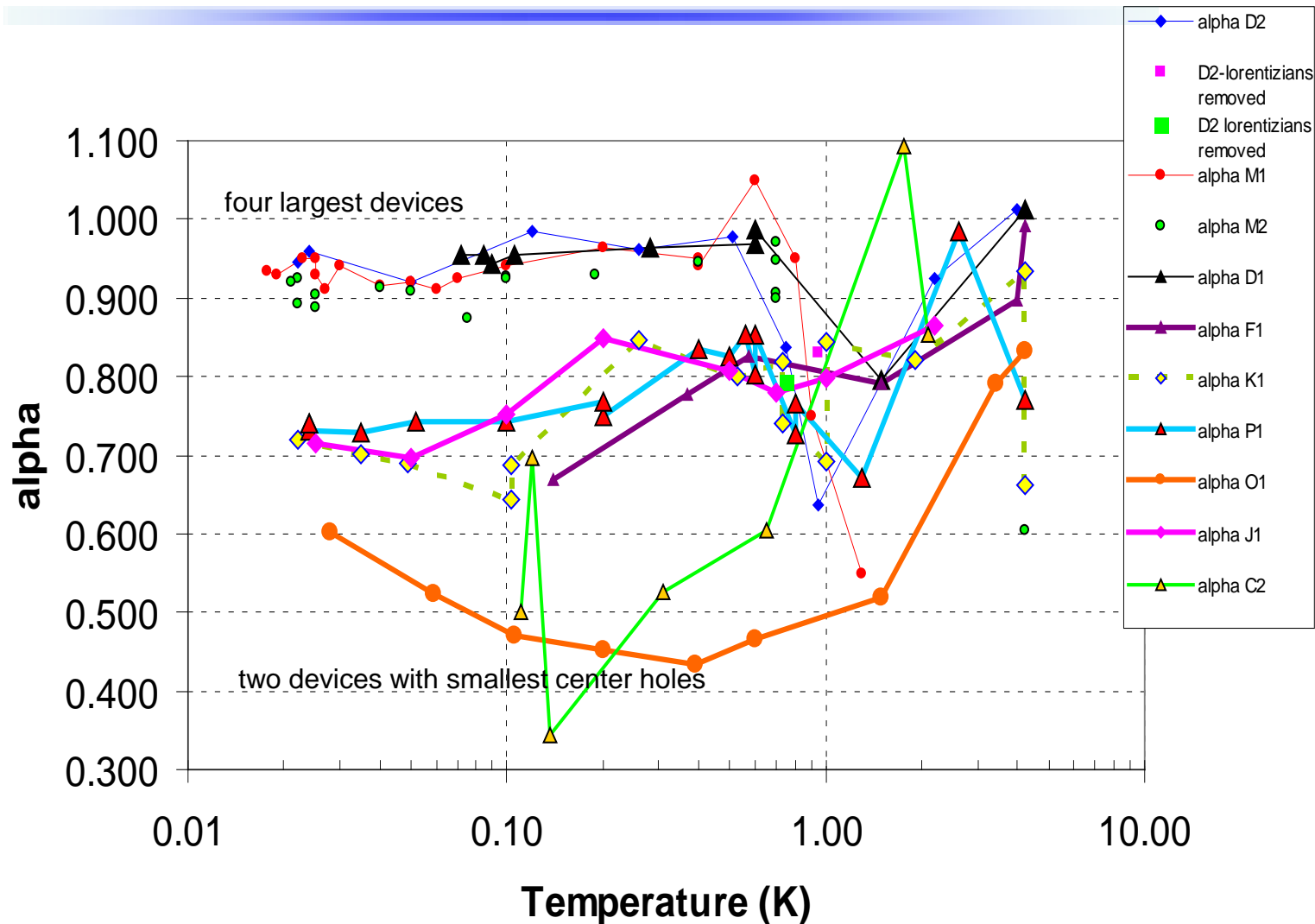

Fig. 1.10 Schematic of a Type F dc SQUID.

Flux noise power spectrum in two SQUIDs



Temperature dependence of the slope α of the $1/f^\alpha$ flux noise



- devices with similar shapes had similar slope α
- small devices tend to have lower alphas with stronger T dependence
- only biggest devices (D1, D2, M1, M2) had α close to 1

An "explanation" for $1/f^{2/3}$ noise

(1) Assume two-level magnetic dipole fluctuators with energy difference $U_i \ll kT$

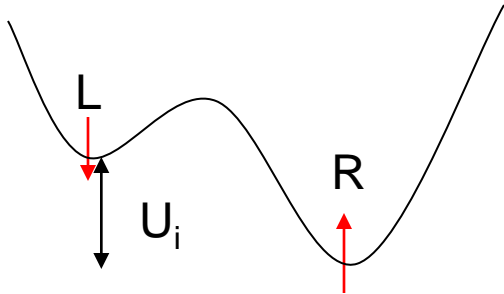

(2) Assume that transitions from the upper to lower state takes time:

$$T_1 = \tau_{LR} = \frac{\tau_o}{F_i^3} = \tau_{RL} = 2\tau_i$$

(3) Assume F_i is an (unknown) physical parameter that has a uniform distribution; $D(F) dF = C'' dF$ and note that:

$$F = \left(\frac{\tau_o}{2} \right)^{-1/3} \tau^{-1/3} \quad \longrightarrow \quad D(\tau) = D(F) \left| \frac{dF}{d\tau} \right| = \frac{C''}{3} \left(\frac{\tau_o}{2} \right)^{-1/3} \frac{1}{\tau^{4/3}}$$

Then the total noise spectrum is

$$S_m^{tot}(f) = \int_0^{\infty} S_{mi}(f) D(F) dF = C'' 4\sigma_m^2 \int_0^{\infty} \frac{dF}{1 + \omega^2 \left(\tau_o / F^3 \right)^2} \frac{\tau_o}{F^3}$$

$$S_m^{tot}(f) = C'' 4\sigma_m^2 \int_0^\infty \frac{dF}{1 + (\omega\tau_o/F^3)^2} \frac{\tau_o}{F^3}$$

now change variables to $y = \frac{\omega\tau_o}{F^3}$

and notice $F = (\omega\tau_o)^{1/3} y^{-1/3}$ $dF = -\frac{1}{3}(\omega\tau_o)^{1/3} y^{-4/3} dy$

$$S_m^{tot}(f) = \frac{C'' 4\sigma_m^2}{\omega} \int_0^\infty \frac{\frac{1}{3}(\omega\tau_o)^{1/3} y^{-4/3} dy}{1 + y^2} y = \frac{C'' 4\sigma_m^2 \tau_o^{1/3}}{3\omega^{2/3}} \int_0^\infty \left(\frac{1}{y^{1/3}} \right) \frac{dy}{1 + y^2}$$



$$S_m^{tot}(f) = \frac{C'' 4\sigma_m^2 \tau_o^{1/3}}{3(2\pi)^{2/3}} \frac{\pi}{2 \sin(\pi/3)} \frac{1}{f^{2/3}}$$

Temperature independent $1/f^{2/3}$ noise...assuming $kT \gg U$.

Putting in all the thermal factors one finds the noise falls off rapidly for $kT \ll U$ and is flat for $kT \gg U$

Key Question: We assumed $T_1 = \frac{\tau_o}{F^3}$, but what is the factor F?

Answer: Don't know if this is the correct explanation (and its not likely it is!). If F does exist, its not known what it is physically.

How do we know its really a flux noise: I-V and I- Φ : SQUID D2 at 0.95 K

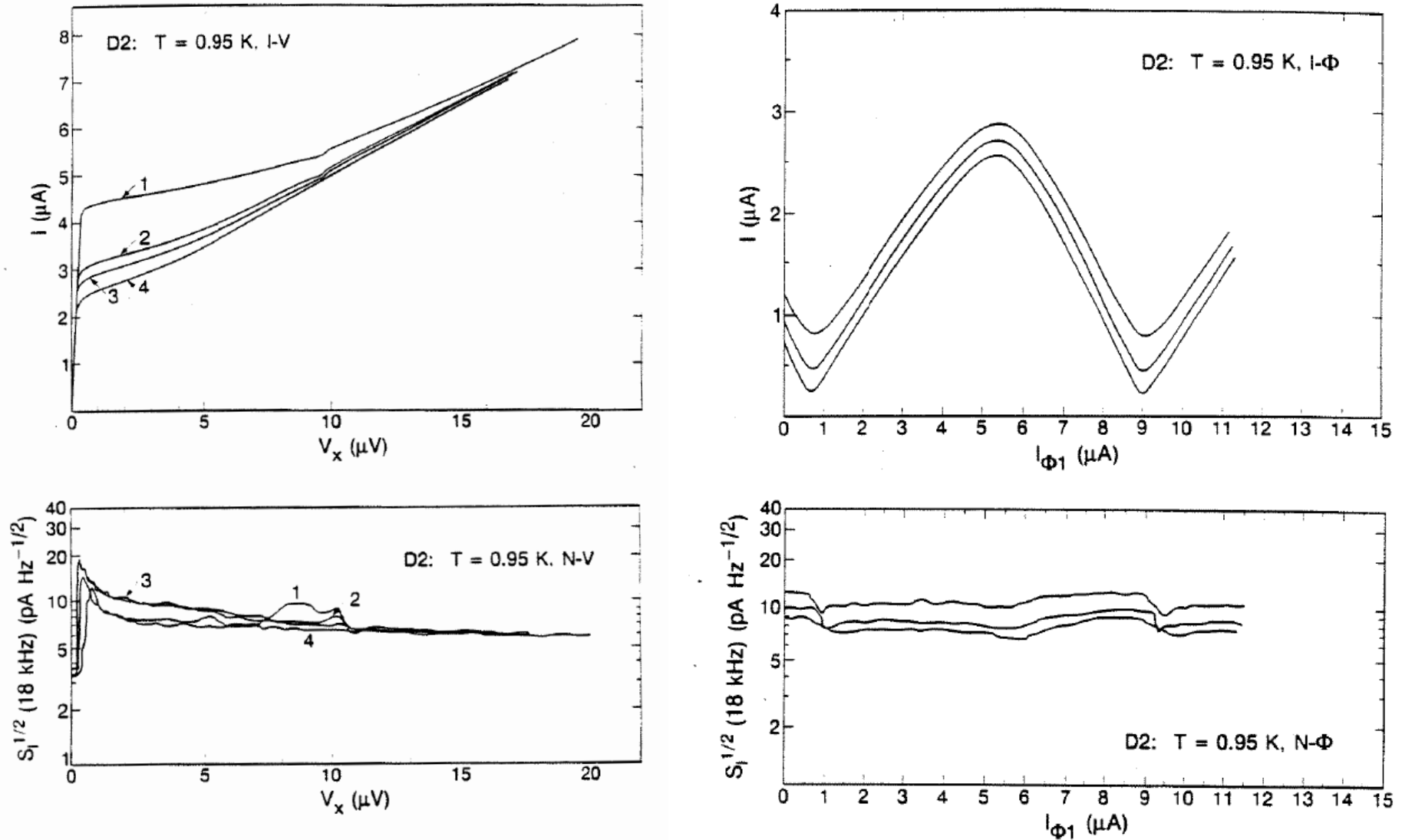

Fig. 4.5 (e) I-V of SQUID D2 at 0.95K, the curves 1 to 4 curves are for fixed flux bias current: 5.33, 7.98, 0, and 0.7 μA , respectively. (f) Noise vs V for the same flux bias currents as in (e). (9-1-86).

Flux noise: Total noise at the output scales with flux gain

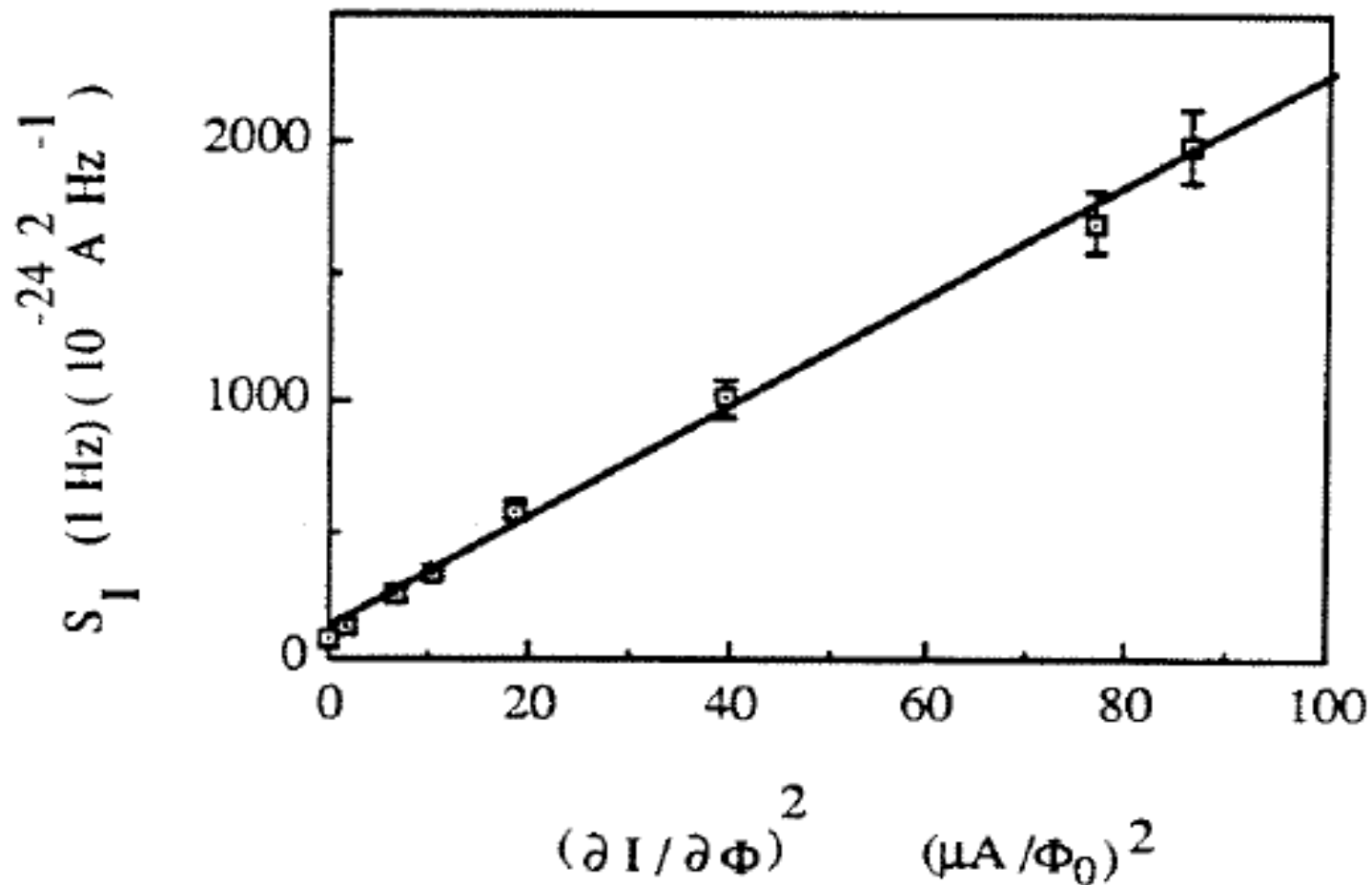
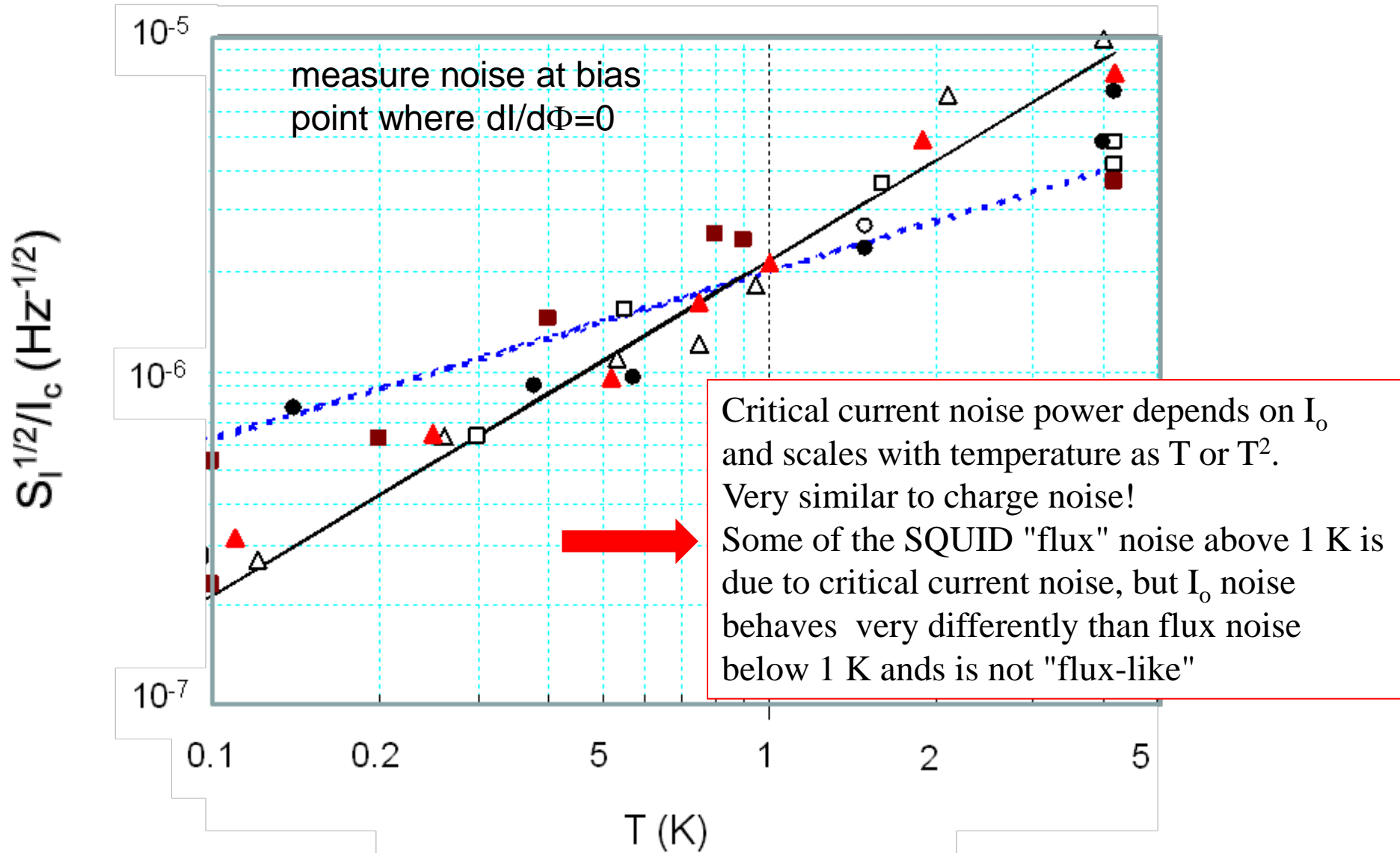

Fig .8.6 (a) Output rms excess current noise at 1 Hz vs. flux gain for SQUID E2 at 110 mK. (b) Output excess noise power at 1 Hz vs. square of flux gain. Solid line is linear plus constant fit.

Critical Current Noise

“Flicker (1/f) noise in the critical current of Josephson junctions at 0.09--4.2 K”,

F. C. Wellstood, C. Urbina, and John Clarke, Appl. Phys. Lett. **85**, 5296 (2004).



Hot electrons in cold SQUIDs (the electron temperature in the shunts)

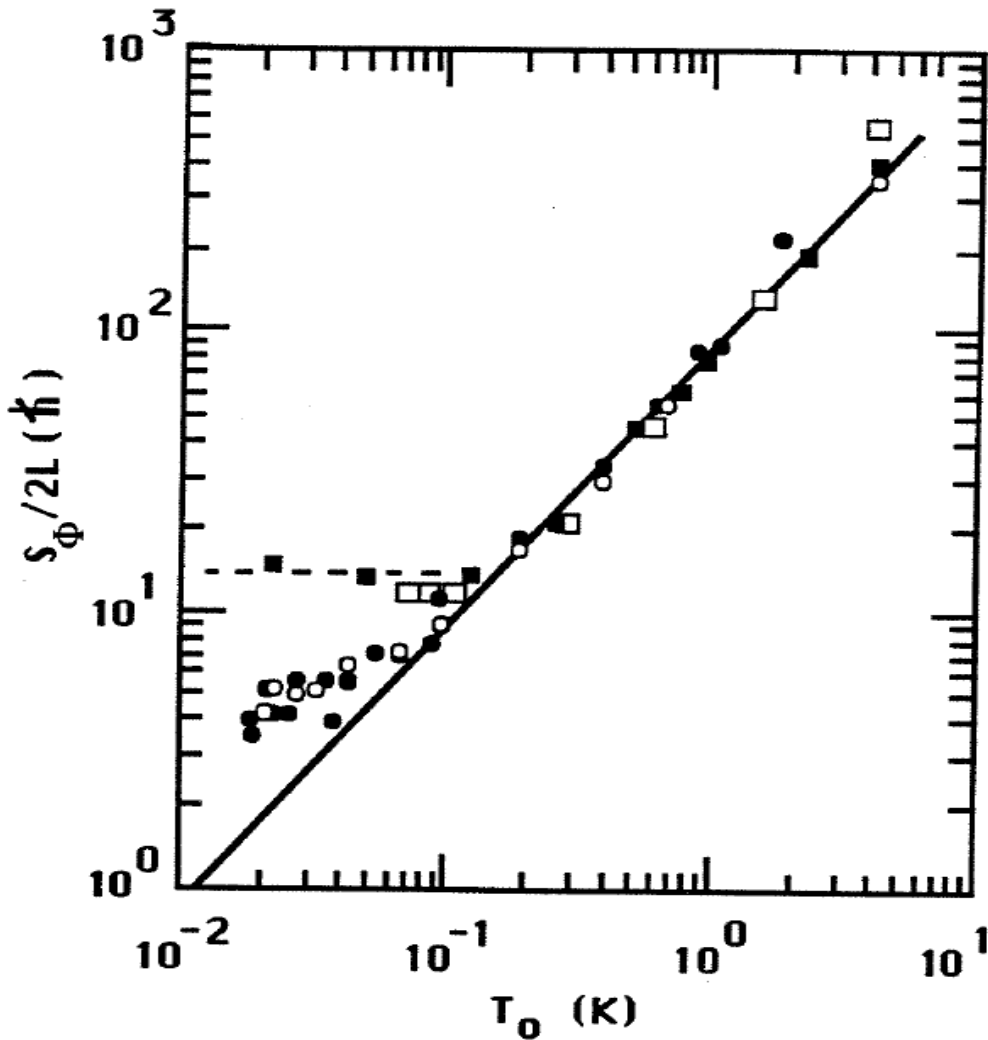

Fig. 11.6 Flux noise energy vs. T_0 for SQUIDs \square D1, \blacksquare D2, \bullet M1, \circ M2. SQUIDs were biased near $\Phi_0/4$, with the operating points given in Table II. Solid line is prediction of Tesche and Clarke.⁽²⁾

Hot electrons in cold SQUIDs (the electron temperature in the shunts)

Table 11.1 Operating points for the SQUIDs D1, D2, M1, and M2. V is the voltage at which the SQUID is biased, I is the current flowing through the SQUID, P is the power dissipated in the SQUID, Ω is the shunt volume, A is the shunt area in contact with the substrate.

Device	V (μV)	I (μA)	P (pW)	P/Ω (Wm^{-3})	P/A (Wm^{-2})	$T_{\text{min}}=(P/\Sigma\Omega)^{1/5}$ (K)
D1	1.1	5	5.4	1.9×10^5	5.6×10^{-3}	0.151
D2	1.1	3.5	3.8	1.3×10^5	$4. \times 10^{-3}$	0.140
M1	1.2	4.5	5.4	1.2×10^3	3.5×10^{-5}	0.055
M2	4.0	5	20.	1.4×10^2	1.3×10^{-4}	0.036

"[Hot-electron effects in metals](#)", F. C. Wellstood, C. Urbina, and J. Clarke, Phys. Rev. B **49**, 5942 (1994).

"[Hot-electron limitation to the sensitivity of the dc superconducting quantum interference device](#)", F. C. Wellstood, C. Urbina, and J. Clarke, Appl. Phys. Lett. **54**, 2599 (1989).

Gaussian distribution of amplitudes

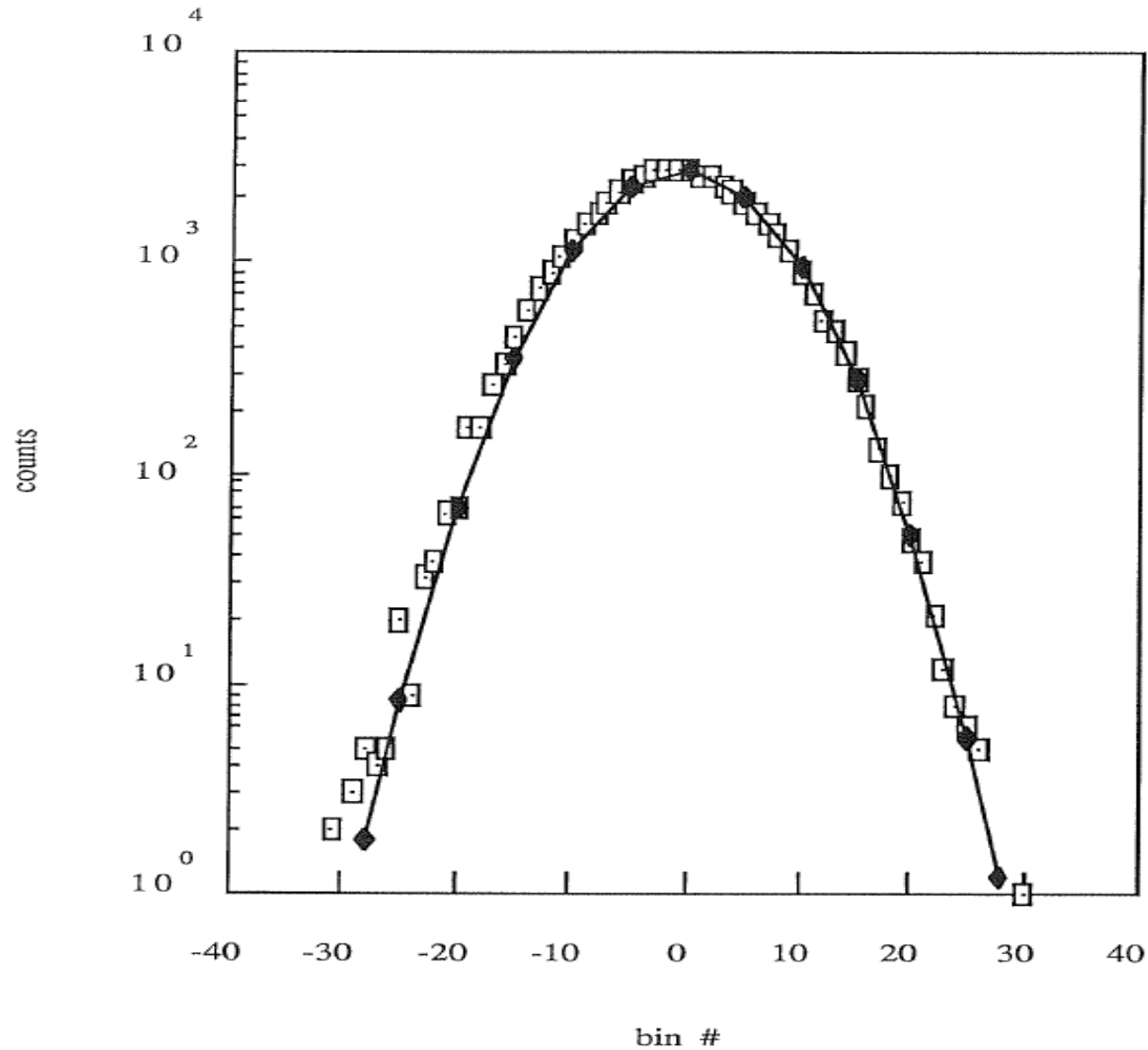

Fig. 8.10 Noise amplitude distribution from SQUID M1.: number of times the output achieved a certain amplitude vs. the amplitude. Solid line is gaussian fit to data.

Parameters of measured devices

Device	Date	T (mK)	$2I_0$ (μ A)	δ	r	α	β	L (nH)
A1	7- 2-85	150	3.66	0.484	0.632	0.45	0.7	0.396
A2 (*)	7-21-85	130	10.8	0.328	0.61	0.6	1.35	0.26
A3 (**)	5-25-85	160	5.78	0.635	0.779	0.22	0.495	0.18
A4	8-10-85	120	0.71	0.89	0.99	0.0	0.16	0.47
A'5	9-16-85	170	6.23	0.392	0.754	0.39	1.2	0.399
A6 (***)	2-19-87	1390	2.04	0.6	0.83	0.18	0.58	0.59
A7 (***)	2-16-87	4200	17.2	0.176	0.953	0.25	4.0	0.48
A8 (***)	2-12-87	4200	3.84	0.53	0.905	0.11	0.79	0.43
B1	10-27-87	160	3.00	0.304	0.709	0.55	1.7	1.17
C1	9-21-85	120	6.15	0.32	0.60	0.68	0.52	0.18
C2	11-15-85	150	5.32	0.618	0.826	0.18	0.55	0.214
C3	1-31-86	1400	21.2	0.292	1.0	0.0	2.1	0.205
C4	2- 6-86	1400	7.1	0.55	0.954	0.06	0.75	0.219
C5	2- 8-86	1400	3.07	0.379	0.766	0.62	0.24	0.16
D1	5-30-86	110	6.34	0.313	0.597	0.64	1.35	0.44
D2	8-29-86	50	4.55	0.414	0.772	0.35	1.1	0.50
E1	2-19-86	95	5.51	0.563	0.96	0.05	0.725	0.27
E2	5-21-86	510	15.1	0.291	0.96	0.13	2.1	0.29
F1	2-27-86	140	5.73	0.32	0.945	0.15	1.93	0.70
G1	3-12-86	110	4.15	0.39	0.76	0.61	0.24	0.12
I1	6-27-87	105	4.13	0.668	0.905	0.09	0.45	0.225
J1	8- 5-86	50	21.6	0.283	0.919	0.25	2.1	0.20
K1	8-14-86	35	11.42	0.23	0.939	0.23	2.9	0.53
M1	10-31-87	25	5.64	0.39	0.99	0.02	1.4	0.514
M2	5- 6-88	20	6.2	0.35	0.71	0.55	1.4	0.47
N2	12-11-87	20	17.7	0.196	0.886	0.5	3.4	0.398
O1	5-19-87	30	1.36	0.97	0.964	0.05	0.03	0.046
P1	6- 5-87	23	1.77	0.352	0.665	0.55	1.25	1.46
NBS1	7-21-87	20		(see Chapter 8)				0.08
FIN1	4-10-88	43		(see Chapter 8)				0.04

(*) 20 turn input coil, left open for measurement of β .

(**) Magnetometer configuration, (geometry described in Chapter 3)

(***) These were variants of the type A, discussed in Chapter 7.

Gradiometric micro-SQUID susceptometer for scanning measurements of mesoscopic samples

Martin E. Huber,^{1,a)} Nicholas C. Koshnick,² Hendrik Bluhm,^{2,b)} Leonard J. Archuleta,¹
 Tommy Azua,¹ Per G. Björnsson,² Brian W. Gardner,² Sean T. Halloran,¹
 Erik A. Lucero,^{1,c)} and Kathryn A. Moler²

¹*Department of Physics, University of Colorado Denver, Denver, Colorado 80217-3364, USA*

²*Geballe Laboratory for Advanced Materials, Stanford University, Stanford, California 94305-4045, USA*

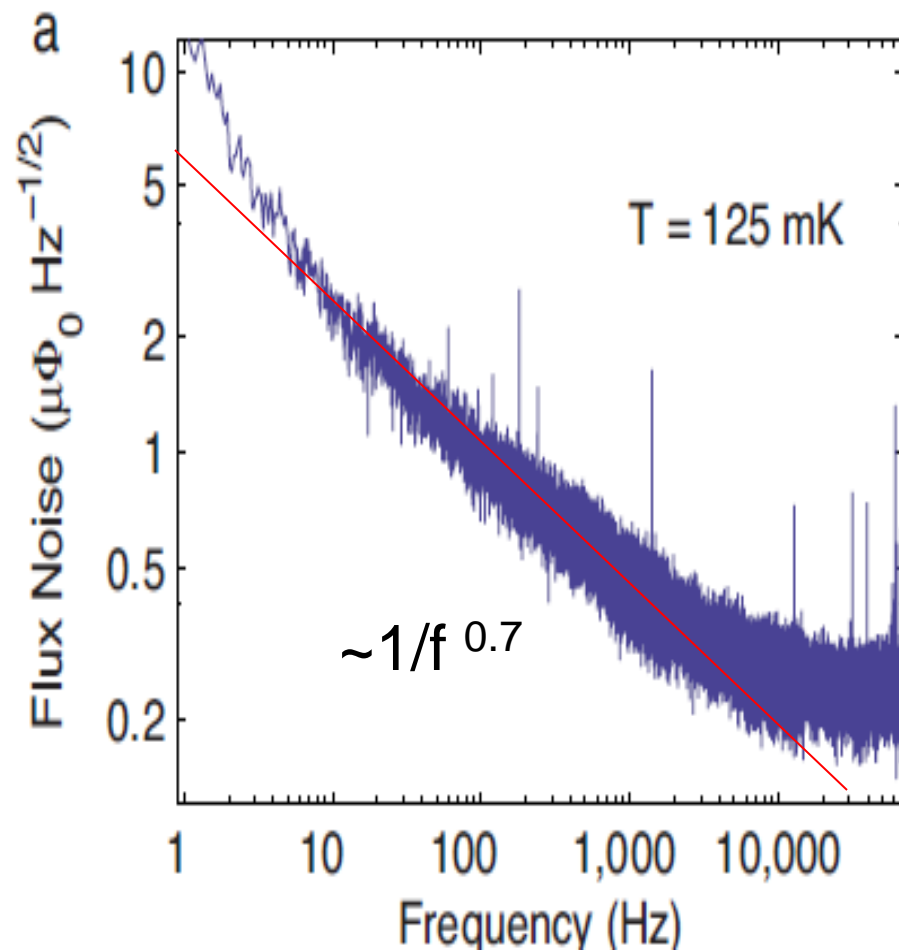
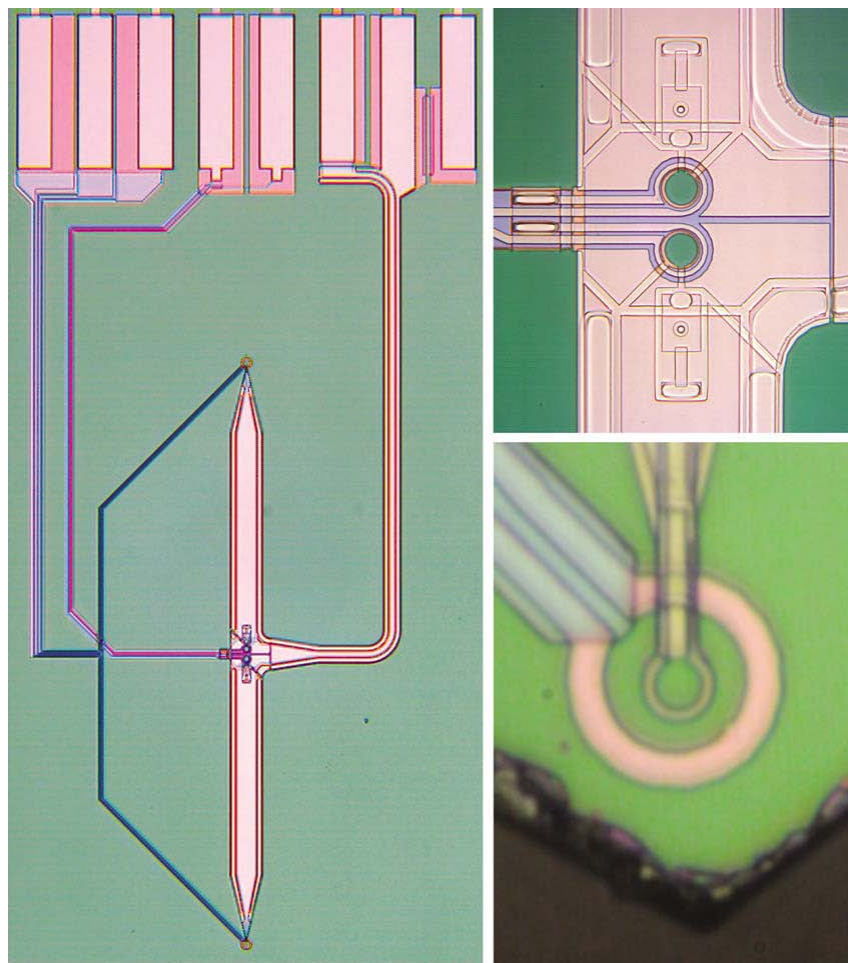

Investigation of Low-frequency Excess Flux Noise in dc SQUIDs at mK Temperatures



D. Drung, J. Beyer, J.-H. Storm, M. Peters, and T. Schurig
Physikalisch-Technische Bundesanstalt (PTB), Berlin, Germany

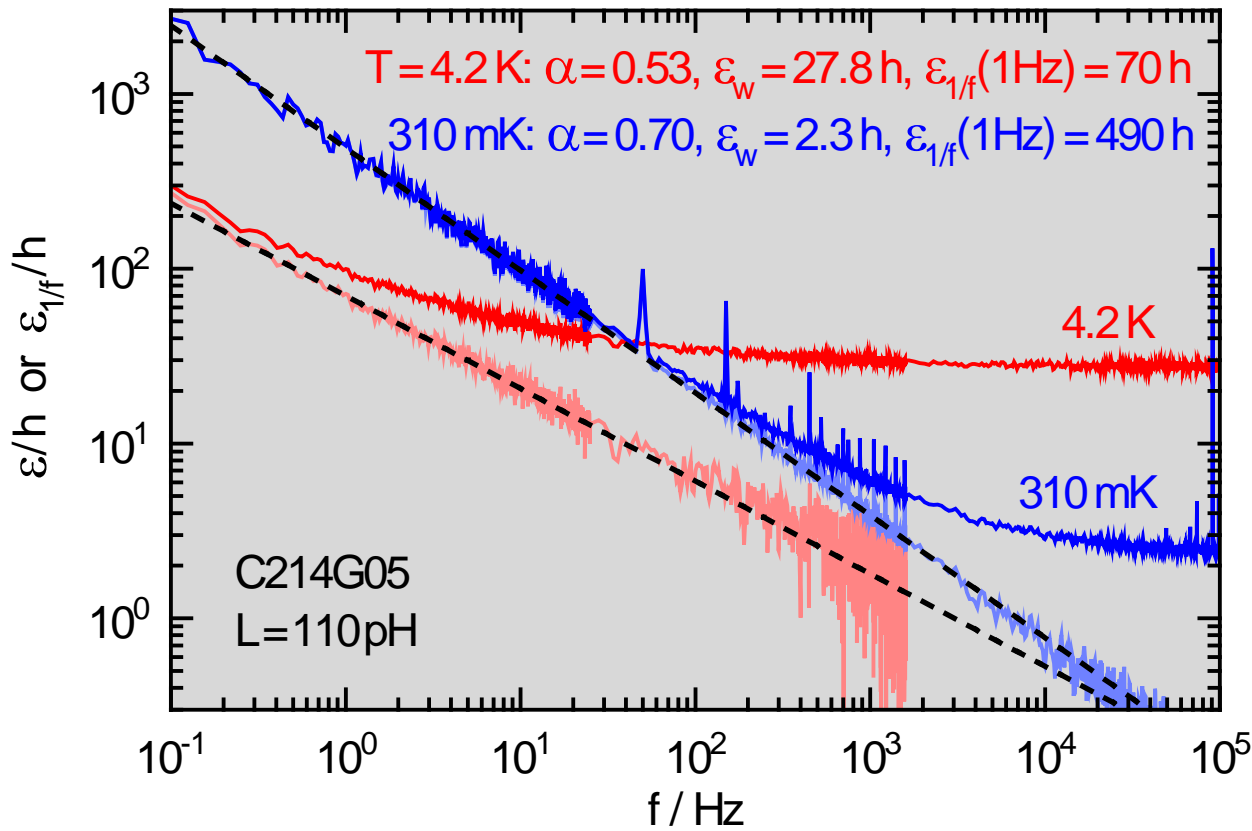

4.2 K \rightarrow < 320 mK: white noise **falls**, but $1/f$ noise **rises**

For this example: mK noise **higher** than 4.2 K noise above ≈ 40 Hz

Conclusions

- Low-frequency excess flux noise has some unusual properties below 1 K:
 - smooth, featureless spectra (except maybe near 0.7K)
 - does not depend on materials... but comes from them
 - does not behave like excess charge or critical current noise
 - increases in magnitude as T decreases below 1 K.... Why?
 - may level out to 5-15 $\mu\Phi_0/\text{Hz}^{1/2}$ below about 0.5 K
 - depends weakly on the SQUID area (can't be B noise)
 - implies significant $\tan(\delta)$ if 1/f noise extends to GHz
- The slope" α of the $1/f^\alpha$ noise depends on the loop geometry
 - α can be significantly less than 1
 - α depends on temperature
 - α depends on geometry of the SQUID... How is this possible?
 - α tended to be smaller for smaller SQUIDs.... Why?
 - recent data on small Al flux qubits suggests $\alpha=1$, but is it?